

Publish Date: June 2023
EVPTYP330 Rev. 1.2.24
USA/North America
©Everlast Power Equipment

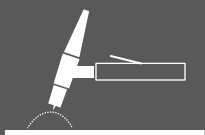

AC/DC
330A

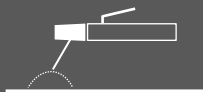

AC/DC
275A

Typhoon 330

Safety, Setup and General Use Guide



FUNCTION: AC/DC TIG with Pulse Function/ DC Stick
PURCHASE DATE:
WELDER SERIAL NUMBER:
OPTIONAL ACCESSORY SERIAL NUMBER:

240V

1 and 3 Phase

Optional 480V 3 phase

Operator's Manual

www.everlastwelders.com

Need Parts? Need Technical Help? Call: 1-877-755-9353

380 Swift Ave. Unit 12 South San Francisco, CA 94080, USA



Welders, Plasma Cutters, Multi-Process

TABLE OF CONTENTS

SPECIAL NOTICE AND CALIFORNIA PROPOSITION 65 WARNING	3
CUSTOMER GREETING AND EXPLANATION OF PROCEDURES	4
WARRANTY AND CONTACT INFORMATION	5
SAFETY DISCLAIMER AND HF WARNING	6
SAFETY WARNINGS, DANGERS, CAUTIONS AND INSTRUCTIONS	7
GENERATOR OPERATION, OPERATING VOLTAGE AND OTHER GENERAL INFORMATION	10
DUTY CYCLE EXPLANATION STATEMENT	11
SPECIFICATIONS: DUTY CYCLE, PERFORMANCE SPECIFICATIONS AND INPUT AMPERAGE INFORMATION	12
SETUP GUIDE: GETTING STARTED, UNPACKING YOUR UNIT, ASSEMBLY AND INSPECTION	13
SETUP GUIDE: CONNECTING YOUR UNIT TO THE POWER SOURCE AND WIRING INFORMATION	15
SETUP GUIDE: SHIELDING GAS INFORMATION AND CONNECTION OF REGULATOR	16
SETUP GUIDE: TUNGSTEN SELECTION AND GRINDING	17
SETUP GUIDE: GETTING STARTED WITH TIG AND STICK BASIC STARTING POINT GENERAL INFORMATION	20
SETUP GUIDE: CONNECTING YOUR UNIT AND READYING TO WELD (POLARITY AND PANEL CONNECTIONS)	21
FRONT PANEL VIEW AND COMPONENT ID	23
REAR PANEL VIEW AND COMPONENT ID	24
CONTROL PANEL LAYOUT	25
STARTING UP THE WELDER	26
CONTROL PANEL OPERATION AND NAVIGATION	27
WELD CYCLE AND GRAPH LINE DETAILS	37
AC TIG SCREEN SETUP, FUNCTIONS AND PARAMETERS	40
DC TIG SCREEN SETUP, FUNCTIONS AND PARAMETERS	44
AC AND DC STICK SCREEN SETUP, FUNCTIONS AND PARAMETERS	47
BACKGROUND MENU SCREEN SETUP AND PARAMETERS OF OPERATION	49
TIG ARC STARTING, REMOTE FUNCTIONS AND OPERATION	50
EXPLANATION OF TIG PARAMETERS, FUNCTIONS AND WELDING TERMS	52
EXPLANATION OF STICK PARAMETERS, FUNCTIONS AND WELDING TERMS	59
TORCH PARTS AND ASSEMBLY	61
7 PIN CONNECTOR PINOUT AND INFORMATION FOR REMOTE	63
TROUBLE SHOOTING: COMMON WELDING ISSUES	64
TROUBLE SHOOTING: ERROR CODES	65
MAINTENANCE	66

IMPORTANT!

Before operating the welder, read this manual from beginning to end. A thorough read-through of this manual is important to help guide you in the safe and competent operation of the welder. This welder is a complex machine with many features that new owners or users may not understand or be familiar with. The manual is written in a way that builds knowledge upon previous information presented in the manual. If sections are randomly read through, details of important information will be missed. In certain sections, where details of operation may overlap, some information may be repeated from previous sections to highlight continuity between different functions and settings. *Though some general welding information is given to illustrate the parameters and functions of the welder, the manual is not meant to train or instruct in welding. The manual's scope and intent is to guide the professional user in safe use of the basic parameters and functions of the welder. Any explicit setting or detail offered in this manual is intended as a general guide, or a starting point, and should not be construed to be a final setting to be applied in any or all circumstances.*

NOTICE:

Product Specifications and features are subject to change without notice. While every attempt has been made to provide the most accurate and current information possible at the time of publication, this manual is intended to be a general guide and not intended to be exhaustive in its content regarding safety, welding, or the operation/maintenance of this unit. Due to multiple variables that exist in the welding field and the changing nature of it and of the Everlast product line itself, Everlast Power Equipment INC. does not guarantee the accuracy, completeness, authority or authenticity of the information contained within this manual or of any information offered during the course of conversation or business by any Everlast employee or subsidiary. The owner of this product assumes all liability for its use and maintenance. Everlast Power Equipment INC. does not warrant this product or this document for fitness for any particular purpose, for performance/accuracy or for suitability of application. Furthermore, Everlast Power Equipment INC. does not accept liability for injury or damages, consequential or incidental, resulting from the use of this product or resulting from the content found in this document or accept claims by a third party of such liability.

WARNING!

California Proposition 65 Warning:

This product, when used for welding or cutting, produces fumes or gases which contain chemicals known to the State of California to cause birth defects and in some cases, cancer. (California Health & Safety Code § 25249.5 et seq.)

 **Warning: Cancer and/or Reproductive Harm**

www.P65warnings.ca.gov

NOTICE:

The Typhoon Series of welders are designed for use by professional welders in commercial settings. Commercial settings are equipped with industrial wiring and power supply. This welder requires a dedicated circuit and special welder outlets that are not typically found in home garages. The higher Amperage outlets and breakers required by this welder may not allow connection to a standard home panel box with out significant modification to meet national electric codes and the input requirements of the welder. (See specifications page of inrush and rated current.) Additionally, use in home settings may cause interference with electronics. **Besides a required dedicated circuit, this welder may also require additional grounding of all metal items and the welder by a commercial electrician to**

THANK YOU! We appreciate you as a valued customer and hope that you will enjoy years of use from your welder. We work to please the customer by providing a well supported, quality product. ***To make sure that you receive the best quality ownership experience, please see below for important information and time sensitive details.***

What to do right now:

1. Print your receipt from your confirmation email that should have been sent to you after your purchase and put it up for safe keeping. If you do not have one, contact us at 1-877-755-9353 (US customers) or 1-905-570-1818 (Canadian Customers). You will need this if anything should ever happen for original owner verification (if bought as a gift, original receipt will still be needed, or explanation sent to Everlast).
2. Read this manual! A large number of tech and service calls are a result of not reading the manual from start to finish. Do not just scan or casually peruse this manual. There are different features and functions that you may not be familiar with, or that may operate differently than you expect. Even if you have expertise in the field of welding, you should not assume this unit operates like other brands or models you have used.
3. Carefully unpack and inspect all items immediately. Look for missing or damaged items. Please report any issues within 48 hours (72 hours on weekend or holidays) of receiving your product,. Take pictures if you are able and contact us at 1-877-755-9353, ext. 207 if any issue is discovered between 9 am and 5 pm Eastern Time M-F (US customers) or at 1-905-570-1818 (Canadian Customers) between 9am and 4 pm weekdays except on Fridays when hours are from 9 am to 12pm Eastern. If outside of the US or Canada, contact your in-country/or regional distributor direct at their service number.

What to do within the next 2-3 days:

1. Make sure your electrical system is up to date and capable of handling the inrush and rated current of the unit. Consult and use a licensed and knowledgeable electrician. If you have downloaded this manual in expectation of delivery, get started now.
2. Make sure this machine is plugged in, turned on, and tested with every process and major feature, checking for proper function. You have a 30 day period to test and thoroughly check out the operation of this unit under our 30 day satisfaction period. If something is wrong, this policy covers shipping on the unit (30 day satisfaction policy applies to the USA only for the 48 lower states and D.C., territories and provinces are excluded) or any incidental parts that may be needed to resolve any issue. After this 30 day period, if you find something wrong with the unit, you will not receive the benefit of free shipping back and forth to resolve this issue. Your unit is still covered under the 5 year parts/labor warranty, but shipping is covered by the customer after the 30 day period is over. The first 30 days of operation with any electronic item is the most critical and if any issue will happen, it will often happen during this time. This is why it is very important that you put this unit to work as soon as possible. Any issue should be reported within 48 hours (72 if on the weekend or holiday). Everlast will not be liable for any shipping after that time.

What to do within the next 30 days:

Visit our website (US customers). Go to www.everlastwelders.com. Navigate to the resources tab and to the “product registration” page to register your product. While keeping your receipt/proof of purchase is still required for verification of ownership, registering will help us keep your details straight and establish a chain of ownership. Don't worry, though, your warranty is still valid if you can't do this. Remember: Always keep your receipt even if you register. You may want to staple a copy to your manual.

What to do if you have a warranty issue or problem with the unit:

1. Unplug the unit. (Also do this before any maintenance or cleaning is done.)
2. Do not attempt a self-repair until authorized by an Everlast representative. This does not include performing routine maintenance such as point gap adjustments or regular internal cleaning. Any third party repairs are not covered under warranty, and can further damage your unit.
3. Within 24-48hours, (or by the next working business day) you must contact U.S. tech support at 1-877-755-9353 ext 207(U.S. hours are 9 am to 5pm Eastern for tech support and 9 am to 5 pm Pacific for the business/sales office). If you are in Canada contact 1-905-570-1818 (Canada hours are 9am to 4pm M-Th, 9am to 12pm Fri). Although phone contact is preferred to establish a warranty claim, you may send an email to tech@everlastwelders.com (US) or mike@everlastwelders.ca (Canada) along with your contact information and brief explanation of the issue and ask for a follow up call. If you contact us via phone, and you do not reach a live person, please leave a brief message with the nature of your problem and your contact information. You should expect a call back within 24 hours. It is also a good idea to follow up the message with an email.
4. Be prepared with as much information as possible when you talk with a tech advisor, including a details of the failure, settings, and application of the unit. ***NOTE: A Proof-Of-Purchase (receipt) is required before returning the unit for warranty or before warranty parts can be sent to you.***
5. Keep in mind that, you may be asked to check a few basic things. Before you call, having a screwdriver and volt/ohm meter at hand is a good idea and will save time. Many issues can be resolved over the phone. If the issue cannot be resolved over the phone/email, you may be given an option to return the unit, or have a part shipped to you, at Everlast's discretion. Keep in mind, you may be asked questions that seem basic, or elementary to your knowledge base. These are not meant to question your knowledge, but rather to make sure nothing is overlooked. However the tech chooses to proceed, please cooperate with the process, even if you think you know what the cause or issue is. You may be asked to check something or open the unit during the diagnosis. This does not void the warranty! Opening the unit is a part of routine maintenance and cleaning. This is an important step. The willingness of the customer to work with tech support can save lots of time and accelerate the warranty process. For

warranty to be honored, you will need to make sure that you follow these guidelines. *Units that are returned without an RMA (issued by the tech support department) may not be repaired under the warranty agreement and you may be charged for the repair and can result in a delayed repair as well.*

What to do if you need setup help, guidance, weld issue diagnosis or have general product compatibility questions.

Call us at 877-755-9353 ext. 204 for welding guidance and general welding issue diagnosis. Or email performance@everlastwelders.com with the basic issue you are having, along with your specific settings, and welding application.

Hey...wait, what is my warranty?

Warranties and service policies and procedures vary from country to country and are maintained and supported by the regional or in country distributor of Everlast welding equipment.

USA Customers Only: For full details on the 5 year parts and labor warranty, 30 day satisfaction policy, terms of sale, and how to proceed with a warranty claim, please visit: <https://www.everlastgenerators.com/standard-warranty>. Accessories are covered by a separate warranty and detailed information can also be found at the link above.

Canada Customers Only: For full details on the 3 year parts and labor warranty, terms of sale, and related policies and procedures, please visit: <https://www.everlastwelders.ca/terms.php>.

Who do I contact?

USA Technical Support:

Email: tech@everlastwelders.com
1-877-755-9353 ext. 207
9am-5pm Eastern (Closed holidays)
Monday-Friday

USA Welding Support and General Product Information:

Email: performance@everlastwelders.com
1-877-755-9353 ext 204
9am-6:30 pm Eastern (Closed holidays)
Monday-Friday

USA Sales and Main Office:

Email: sales@everlastwelders.com
1-877-755-9353 ext 201
9am-5pm Pacific (Closed holidays)
Monday-Friday

Canada Technical Support:

Email: mike@everlastwelders.ca
905-570-1818
9am-4pm Eastern Monday-Thursday
9am-12pm Eastern Friday

Canada Sales and Main Office:

Email: sales@everlastwelders.ca
905-570-1818
9am-4pm Eastern Monday-Thursday
9am-12pm Eastern Friday

Other Countries and Regions:

Visit the U.S. Website @ www.everlastwelders.com and click on the flag of the country or region represented that is closest to you. If your country or region is not found, call the U.S. office at 1-650-588-8588 between the hours of 9am to 5pm Pacific, Monday through Friday.



Safe operation and proper maintenance is your responsibility.

Everlast is dedicated to keeping safety a top priority. While we have compiled this operator's manual to instruct you in basic safe operation and maintenance of your Everlast product, it is no substitute for observing safe welding practices and behavior. Safe welding and related cutting operations require basic knowledge, experience and ultimately the exercise of common sense. **Welding does significant hazards to your health and life! Exercise extreme caution and care in all activities related to welding or cutting. Your safety, health and even life depends upon it.**

WARNING! If you do not have proper knowledge or capability to safely operate this machine, do not use this machine until proper training has been received!

While accidents are never planned, preventing an accident requires careful planning. Stay alert!

Please carefully read this manual before you operate your Everlast unit.

The warranty does not cover damage or harm created by improper use, neglect of the machine or failure to follow safe operating practices.

NOTICE:



Welding and cutting operations may generate undesirable High Frequency (HF) and EMF energy. This can interfere with surrounding electronic equipment such as computers, routers, CNC equipment, televisions, radios, fluorescent lighting etc. If disturbance in surrounding electrical and electronic equipment is noted, consult a licensed electrician to help properly ground surrounding equipment to limit the interference. This machine may cause GCFI and ground fault outlets to malfunction. This unit is designed to be operated on a dedicated, properly grounded circuit.

Safety Warnings, Dangers, Cautions and Instructions



NOTICE. This unit manual is intended for users with basic knowledge and skillset in welding. It is your responsibility to make certain that the use of this welder is restricted to persons who have read, understand and follow the warnings and instructions in this manual. If you or the operator needs further instruction, contact Everlast welding support at 1-877 755-9353 ext. 204 or seek qualified professional advice and training.



WARNING! High Frequency (HF) energy can interfere with the operation of pacemakers and can damage pacemakers. Consult with your physician and pacemaker manufacturer *before* entering an area where welding and cutting equipment is in operation and *before* using this welder. Some pacemakers have limited shielding. Alert any users or customers



WARNING! Use approved safety glasses with wrap around shields and sides while welding and working in the weld area or serious eye damage or loss of vision may result. Use a grinding shield in addition to the safety glasses during chipping and grinding operations.



WARNING! When welding always use an approved welding helmet or shielding device equipped with at least an equivalent of a shade 9 or greater. Increase the shade number rating as amperage increase over 100 amps. Inspect helmet for cracks in lenses and in the helmet. Keep lens covers in good condition and replace as necessary.



WARNING! Welding/cutting operations carry inherent risks which include but not limited to possible cuts burns, electrical shocks, lung damage, eye damage and even death. Take all appropriate measures to use proper Personal Protective Equipment (PPE). Always use leather welding gloves, closed toe (preferably reinforced or steel toe leather shoes, and long-sleeved flame resistant clothing (i.e. denim). Do not wear Poly/Nylon blend materials.



DANGER! Welding poses shock and electrocution risks. Keep this welding equipment dry. **Do not weld in the rain or where moisture accumulates.** Use dry, rubber soled shoes, gloves and clothing when welding. Do not rest or contact work clamp (ground) when welding. Keep all parts of the body insulated from the part being welded when possible. Do not touch both terminals or connections at the same time. Consider all welder parts to be “live” at all times even if no welding is being performed. Do not use frayed welding cables.



CAUTION! Fires are possible but also preventable while welding. Always remove flammable rags, papers, and other materials from the weld area. Keep rags stored in an approved flame proof canister. Keep a fully charged fire extinguisher at hand. Remove any fuels, oils, paint, pressurized spray cans, and chemicals from the weld area. Make sure any smoke/fire detectors are function properly. Do not weld on tanks, drums or barrels, especially if pressurized or sealed. Do not weld on any container that previously held fuel or chemicals. Make sure the weld area is clear of flammable materials such as grass or wood shavings solvents and fuels. Do not wear frayed or loose clothing. Visually inspect and recheck the work area after welding looking for smoldering debris or flames.

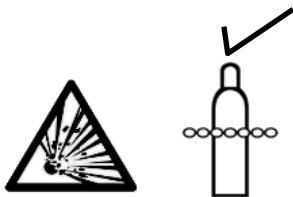

WARNING! Welding gas cylinders are under high pressure. Keep all gas cylinders upright and chained to a cart or held safely in a safety holding pen. Never transport gas cylinders in an enclosed car van or other vehicle. Transport gas cylinders securely. Keep all cylinders capped while not in use or during transport. Replace the cap on the cylinder when it is going to be more than 24 hours before use. Do not use or attempt to repair faulty regulators. Never weld on gas cylinders. Keep gas cylinders away from direct sparks.

Safety Warnings, Dangers, Cautions and Instructions



DANGER! Welding and cutting operations pose serious inhalation hazards. Some of these hazards are immediate while others are cumulative in their effect. **Do not weld in enclosed spaces or in areas without adequate ventilation.** Fumes and gases released in the welding and cutting operations can be toxic. Use fans or respiration equipment to insure adequate ventilation if you are welding in a shop or garage area. **Do not weld on galvanized metal under any circumstance. You may develop metal fume fever. Symptoms are similar to lu-like symptoms. Seek medical advice and treatment if you are exposed to galvanized welding fumes.**

If you experience any eye burning, nose or throat irritation while welding, these are signs that you need more ventilation.

If you feel these symptoms:

- Stop work immediately and relocate work area with better ventilation.
- Wash and clean your face and hands.
- Stop work completely and seek medical help if irritation persists



DANGER! Never use brake cleaner or any chlorinated solvent to clean or degrease metal scheduled to be welded or other related equipment in the area being welded. The heating of this cleaner and its residue will create highly toxic phosgene gas. Small amounts of this vapor are harmful and can lead to organ failure and death. If degreasing of a part is necessary, use Acetone or an approved pre-weld cleaner. Use the proper personal protective equipment (PPE) when handling any cleaners/solvents.



DANGER! People with pacemakers should consult a physician and pacemaker manufacturer before welding. There is a potential for damage or serious malfunction resulting in death. High Frequency energy (HF)/Electromagnetic Fields generated during welding can interfere with pacemaker signals, even permanently damaging it. Some pacemakers offer some shielding, but restrictions regarding amperage and HF/HV starting of TIG arcs may be placed upon the individual. Warn all potential bystanders that they should exit the work area if they have a pacemaker or similar medical equipment before welding. Consult with a Physician if a pacemaker is expected to be implanted.







DANGER! Never defeat or modify any safety guards or shields. Keep all safety covers and shields in place.

Never place your fingers in or near a fan shroud or insert any object into the fan(s).



WARNING! The intense flashing and strobing effects that are common with welding processes, particularly when using the Pulse function may cause seizures in people with a history of photo-sensitive Epilepsy. Be mindful of others in the welding area who may have such sensitivities. Keep them clear of the area.

Safety Warnings, Dangers, Cautions and Instructions

	<p>CAUTION! Trip Hazards exist around welders. Cords, cables, welding leads and hoses pose a trip hazard. Be aware of their location and inform others of their location. Tape and secure them so they will stay out of high traffic areas.</p>
	<p>CAUTION! Welded metal can stay hot long after welding is completed. Burns may occur. Always wear gloves or use tongs/pliers when handling welded or cut metal. Remember the heat from the metal may catch other material on fire. Always have a fire-proof area ready to place welded components until they fully cool. Use soap stone or a metal marking marker to label the metal as “HOT” to serve as a reminder to all present in the area.</p>
	<p>CAUTION! Welding and cutting operations generate high levels of ultraviolet (UV) radiation which can burn and damage skin and eyes. The intensity is so high that exposed skin and eyes can burn in a few minutes of exposure. Minimize direct skin and eye exposure to this intense form of radiation by using proper PPE and sun screen where appropriate.</p>
	<p>CAUTION! Do not allow bystanders. Do not allow others without proper Personal Protection Equipment (PPE) suitable for welding to stand in the welding area or to observe welding and welding related activities. If protection is not readily available, use a welding screen to separate the welding area from the rest of the area. If no protection or screen is available, physically exclude them from the welding area by a wall or other solid divider. Keep all pets and young children away from the welding area.</p>
	<p>CAUTION! Electromagnetic Fields can be generated by this welder and radiate into the work place. The effect of EMF is not fully known. Exercise caution when welding by: NOT draping welding leads (guns/cables) over your shoulders or arms, NOT coiling them around your body, NOT inserting yourself directly between the cables, and by NOT contacting the unit while welding. DO keep the work clamp connected as close as possible to the area of the weld and directly to the object being welded whenever possible.</p>

**NOTICE:

If any electrical disturbance is noticed as a result of the High Frequency operation of this unit during arc starting, the HF service bolt located on the rear of this unit should be connected directly to a 12 gauge wire that is bonded directly to an outside copper ground rod driven into moist soil. (see location on rear panel page) Additionally, all metal items including any metal frame or sheeting of the building should be connected and grounded to separate copper ground rods driven into the ground at 10 foot intervals around the perimeter of the building. This includes items such as tables, carts, rack material, metal surrounds, etc. that may act as “antenna” to radiate/absorb HF energy. Additionally, all cords and welding leads should be twist-

Important Information: Operating this unit with a generator or other off-grid service.

This welder should only be operated on a generator certified by its manufacturer to produce clean power. Clean power is equivalent to the quality of household or shop/garage type power. This means the generator must have 5% or less total harmonic distortion (THD) of the Sine wave. If you are unsure of the power output type of the generator, contact the manufacturer of the generator for verification. *Do not operate on square wave or modified square wave generators or converters/inverters or damage or malfunction may occur. Damage caused by running this welder off of "dirty" power or modified sine waves may not be readily apparent and is usually cumulative in nature. However, damage may present itself immediately. The damage caused by running this welder on "dirty" power usually leaves internal tell-tale signs and damages specific parts.*

When operating on 240V 1 phase generator power, you will need a minimum size of 15,000 Surge Watts. Ideally, it is recommended for use with 16,000 Surge Watt generators or larger. Operating the unit on under-powered generators and/or on generators not rated with 5% or less THD can damage your unit. *The generator manufacturer determines this rating, not Everlast.* Do not assume that a name brand generator, or a "new" generator provides clean power. Price paid does not guarantee a clean power output either. There are multiple brands at various price points capable of producing clean power. Investigate this before purchasing a generator. The manufacturer will usually state that a unit is clean power in the advertising information and will state actual THD. If the manufacturer does not state it, contact the manufacturer directly for actual THD.

NOTICE! Operation of this unit with a generator not stated to provide clean power (5% or less THD) by the manufacturer of the generator is prohibited and will void the warranty. Use only with generators/inverters/converters that produce an equivalent type of sine wave used in shops, homes and "shore" type systems. **Do not use with any off-grid power delivery system that produces more than 5% Total Harmonic Distortion (THD).**

WARNING! Do not start or stop the generator with the welder switched on. Never use the generator in ECO mode or an auto-idle mode. Even with a clean power rated generator, this action can damage the unit. *Turn on the welder only after full generator R.P.M. has been achieved and the engine is sufficiently warmed up.* Closely monitor generator fuel level so that the engine R.P.M doesn't drop or completely shut down with the welder plugged in. **For best practice: do not start or stop the generator with this welder plugged in, even if it is turned off. Unplug the welder before shutting down the generator.**

If using with a welder generator, make sure the manufacturer has determined that the generator portion produces a clean sine wave. Many older models do not. Some newer models use "divided" power between welding and generating and cannot supply the full power to the welder unless the fine current control knob is turned to maximum. Do not use this unit with such welder/generators unless the Power/fine current control is turned to 100%. Some welder generators do have a separate alternator for generating power. If this is the case, just be sure not to weld or load the machine while this unit is in use.

WARNING! Always make sure any generator or welder generator is properly grounded, according to local code and manufacturer's instructions. Ground the machine per the generator manufacturers instructions to meet code. Improperly grounded generators may damage the machine and more importantly may cause severe injury or death. Damage resulting from improperly grounded generators is not covered under warranty.

Single and Three Phase Operation:

The standard Typhoon unit may be operated on either single phase or three phase 220/240V supply power. It can also be operated on 208V 1 phase or 3 phase power as long as the power supply does not drop below 200V during peak demand times. Operating on 208V will increase Amperage draw.

If 208 or 240V 3 phase is present, the wiring must be configured to use only the black and white conductors (power legs) of power that produce approximately 110-120V to ground and measure nominally between 208 and 240V between any two conductors. The green wire should be wired for ground. The red wire should be used only for three phase as L3. Use the red wire for high voltage power leg if it is a Delta system. The power conductors are also tagged for single phase or three phase operation as a reminder. Installation on single phase or three phase power should present no issues if codes are followed and proper sized conductors are used. *The optional 480V Typhoon model may only be operated on 3 phase power. The voltage can range between 460V to 485V 3 phase for this optional unit.*

Breaker Sizing and Wiring Requirements

Before installation of this unit in any facility, always consult a licensed local electrician familiar with the requirements of properly wiring a welder into the electrical supply. Refer to the National Electric Code (NEC) and local codes. If needed, refer the electrician to Article 630 of the NEC during consultation to determine proper application and wiring needs. Use the I_{1MAX} and the I_{1EFF} ratings listed above to determine the proper breaker and conductor (wire) sizing required. Everlast welders are designed around use in industrial wiring applications and are intended to be used with modern electrical systems. Household wiring may need to be upgraded before this welder may be installed.

Optional 480V 3 phase units are not suitable for small shops or home operation unless provisions have been made for 3 phase supply. **Do not with use a rotary-type/mechanical phase converter or damage may result.**

WARNING! Do not modify the welder wiring. This unit meets the standards for conductor sizing on the power cable and takes into account power cable length, duty cycle and rated current.

Specifications

Duty Cycle

Duty Cycle is defined per North American Specifications as the amount of time out of a 10 minute period in which the unit can operate when tested at 40° C (104° F). For example, this unit has a duty cycle of 40% at maximum output. That means that the unit can be operated for 4 minutes out of 10 minutes at 330A (TIG). For this unit, the 40% rating is at the maximum output of the machine whether in TIG or Stick Mode. This rating means it be continuously, or intermittently operated during the 10 minute period of time up to the duty cycle limit.

This rating standard (United States) is based on a maximum ambient temperature of 40°C. Operating above this point, or at lower temperatures with high humidity may reduce the duty cycle rating. Of course, the duty cycle may increase somewhat as ambient temperature drops. Regardless, this unit's duty cycle is not controlled by a timer. Rather, this unit is equipped with a heat sensor located on a heat sink near the critical power components of the welder. If the operating temperature of the unit is exceeded, welding output will stop and an over-temperature warning light/error code will be displayed on the panel. **If a duty cycle event is registered, do not turn the unit off!** Allow the welder to continue to run at idle for at least 10-15 minutes until the temperature has fallen enough to reset the sensor and over-temperature warning light. *Even if the unit resets, allow the unit to cool for a full 15 minutes, or the duty cycle will be more quickly triggered since the unit resets just below the heat threshold. The fan(s) must continue to run for a full 15 minutes to cool the unit properly after the duty cycle shut down has occurred. Be sure to set the fan to run continuously instead of on-demand.* After 15 minutes of cooling, you may switch the unit off if you are finished welding. If the unit does not automatically reset after 15 minutes, turn the unit off. Wait for 15 seconds before turning the machine back on. If the unit does not reset, contact technical support for further advice and assistance. As a best practice, when you have completed welding and have been welding continuously for extended periods of time, keep your unit on for 10 additional minutes without welding to allow it to cool.

The intentional and/or repeated triggering of the duty cycle protection feature on this unit will shorten the lifespan of the unit's electronics and can weaken internal components. The effect of overheating your unit repeatedly takes a cumulative toll on the welder and can lead to early failure.

WARNING!

This unit is not designed for Air Carbon Arc Gouging or Cutting. Do not use this unit for this application. It is not designed to sustain the high volt and long arc characteristics needed for Carbon-Arc use.

WARNING: Any Carbon-Arc use will instantly void the warranty! Do not be tempted to use Carbon-Arc Gouging or Cutting under any circumstances, regardless of the electrode diameter that is intended for use.

NOTICE:

This manual has been written to guide in safe operation of the Typhoon welder. It is important to note that due to our continual effort to improve and advance the design of the series, units currently in production may have updated designs and programming improvements not found in earlier production models. Older models may not be updateable without returning the units for major service at customer's expense. Realistically, updating previous generations of units, to current model specifications and configuration may not be possible or practical. Additionally, if an update is deemed possible, this is not considered to be a part of warranty work and is not eligible for return/exchange. Some updates and modifications are not possible due to complete revisions of parts and internal design changes that are incompatible with the older designs. Major changes and differences in operation and specifications are noted where possible in this manual. However, some functions and specifications, not affecting overall function or operation, may change from time to time without further notice or update from Everlast. *Everlast accepts and bears no responsibility, nor provides any guaranty or promise, to update programming, features, functions or ratings for older units already in service, free of charge or otherwise unless specifically stated in writing.*

Specifications

Product Specifications

Construction Type	Digital IGBT Inverter-Based Design with 5.1" HD (720) Screen. (Diagonal Measurement)
Input Voltage/ Hertz/ Phase	220V (± 15%) 50/60 Hz 1 and 3 Phase (480V 3 phase Optional)
I _{1MAX} Current Rating (Inrush Amps)	220V 1phase @ 65A 220V 3phase @ 32A (Optional 480V 3 phase @ 18A)
I _{1EFF} Current Rating (Effective Rated Amps)	220V 1phase @ 42A 220V 3phase @ 21A (Optional 480V 3 phase @ 12A)
OCV/ OCV with Voltage Reduction Device Selected	TIG: 105V, Stick: 85V / With VRD Selected <24V)
TIG Duty Cycle @ Rated Output (Rated at 40° C/104° F) *	40% @ 330A/ 60% @ 270A/ 100% @ 210A
Stick Duty Cycle @ Rated Output (Rated at 40° C/104° F) *	40% @ 275A/ 60% @ 220A/ 100% @ 170A
TIG Output Range V/A (AC/DC)	AC: 10.1-23.2V/ 3-330A / DC: 10.1-23.2V/ 2-330A
Stick Output Range V/A (AC/DC)	AC/DC: 20.4-31V/10-275A
Independent Amplitude	The Electrode Positive Value can be set independently at 10% to 125% of the Electrode Negative Value.
TIG Start Type	Solid State HF (Simulated HF, No points), Lift with Remote, Live Lift
Pre Flow / Post Flow Gas Time	PREFLOW: 0-30 Seconds; POSTFLOW: 0-60 Seconds
Start Amps (Initial Current); End Amps, AC/DC (Crater Current)	START AMPS: AC 3A, DC 2A END AMPS: AC 3, DC 2A (In manual setting for Tungsten Size Selection.*)
Upslope/ Downslope (Ramp up/Ramp Down Current) Time	UPSLOPE: 0-30 Seconds DOWNSLOPE: 0-60 Seconds
TIG Pulse Frequency Hz (Standard DC/Standard AC Advanced AC)	Std. Pulse DC .1-999.9Hz Std. Pulse AC .1-500Hz Adv. AC Pulse .1-10Hz
DC TIG Pulse Wave Forms	(4) Advanced Square, Triangular, Sine, Trapezoid
TIG Pulse Time On (Duty Cycle)	5-95% Peak (Welding Amp Time vs Pulse Amp Time)
TIG Pulse Amps (Background Current)	3-100% of Peak (Welding Amp Value)
AC Wave Forms	(5) Adv. Square /Soft Square /Trapezoid/Triangular/Sine (Stick allows Advanced Square Only for AC Output)
AC Split Wave Form Control	Both Electrode Positive (+) and Negative (-) halves of the AC cycle can be assigned a specific wave shape.
AC Frequency	20-400 Hz (AC TIG and AC Stick)
AC Balance (Cleaning, % of Electrode Positive)	5-70% of Electrode Positive (+) (AC TIG and AC Stick)
TIG Spot Timer	0-10 Seconds (in Tenths)
Stitch Timer	0-5 Seconds (in Tenths) Set to 0 to turn off activity of the Stitch function.
DC TIG Fast Tack (Cold Weld)	10-250 Milliseconds (.001 to .250 Seconds)
DC TIG Fast Tack Stitch Timer	0 -250 Milliseconds (0 to .250 Seconds) Set to 0 to turn off operation of the function.
Stick Arc Force Control	0-100% over set Amperage. Limited to the maximum available overhead current.
Stick Hot Start Amps (Intensity)	0-100% over set Amperage. Limited to the maximum available overhead current.
Stick Hot Start Time (Duration)	0-2 Seconds
Ant Stick Function (Stuck Rod)	Yes, lowers Amperage when rod is stuck for easy removal.
Stick E6010 or EXX10 Capable (Cellulose Type Electrodes)	Yes, with E6010 selected.
TIG Gun Type/Length/ Connector Type	NOVA Rigid-Neck 9 Series Air Cooled, 12.5 ft. (4m) DINSE 35/50mm ² (1/2" nominal diameter) NOVA Rota-Flex 20 Series Water-Cooled, 12.5 ft. (4m) DINSE 35/50mm ² (1/2" nominal diameter)
400A Work Clamp with Cable Length	9.5 ft. (2m) DINSE 35/50mm ² (1/2" nominal diameter)
300A Stick Electrode Holder Length	9.5 ft. (3m) DINSE 35/50mm ² (1/2" nominal diameter)
Power Cable Length	6.5 ft. (2m)
Power Plug Type for Single Phase Operation	NEMA 6-50P (Standard 240V Welder Type, 3 Wire in North American Markets Only.)
Cooling Type	Fan with full-time, thermo-controlled 60° C (140°F) activation or on-as-demanded when arc start settings.
PowerSet Mode (Synergic Assist for User Setup)	For both TIG and Stick modes.
Dimensions with Handles installed (installation optional)	17.8" H X 9.6" W X 25.4" L (453mm H X 244 W X 646mm L)
Weight (Bare Unit)	68 lbs. (31 Kg)
Ingress Protection Rating	IP21S
Operating Temperature Range	14-104°F/ -10-40°C (If operated higher than 104°F/40°C then duty cycle will be lowered significantly.)
Recommended Water Cooler and Welding Cart (Optional)	Water Cooler: PowerCool 375 Welding Cart: PowerCart 375 or PowerCart 330

* Early models did not have manual setting for Tungsten size selection. Minimum Start Amperage was 6A for .040" Tungsten.

Setup Guide

Getting Started

UNPACK THE UNIT.

Upon arrival, you will need to completely unpack your unit, and check things over. This is a time sensitive matter. Do not delay or hold the welder unopened in the box. First, make sure the unit is opened from the top. Be careful with using knives and sharp objects so you won't cut cords and cables inside the boxes. Lay all items out and inspect them.

You should have the following in your box:

1. Welder.
2. NOVA Foot pedal 25 ft. (NOVA Wireless Optional).
3. 9 Series Air-Cooled Torch (NOVA Rigid/Straight Neck) 12.5 ft.
4. 20 Series Water-Cooled Torch (NOVA Rota-Flex) 12.5 ft.
5. Torch Switches(x2) for 2T/4T use (loose or attached to torch).
6. 300A Stick Electrode Holder (approx. 9.5 ft with cable).
7. 400A Bronze Work Clamp (approx. 9.5 ft with cable).
8. TIG Consumable Starter Kit (x2) Tungsten not included.
9. Argon Regulator, floating ball type with hose.
10. *Not Pictured:* 6 foot Power Cord Installed (No Plug).



NOTICE:

The foot pedal may arrive with the top separated from the bottom. This is not damage. The top can easily be installed on the bottom, by aligning the pivot pins with the corresponding holes for the pins located in the top. The pins are spring loaded and can be squeezed so that the top slides down onto the pins. The pins will pop out into the holes and allow the top to pivot once the pins and holes are properly aligned. You may need to make sure the pressure return spring is flipped so that it pushes back against the pedal as it is assembled. Similarly, the foot pedal may be disassembled simply by pressing in on the ends of the pins on both sides to remove the top.

When you receive your package, inspect the unit for damage. Check for the presence of and the general condition of the accessories. Some slight rubbing or chaffing of some of the accessories may be present. This is considered normal. If any item is damaged or missing, please inform Everlast within 72 hours of product receipt. See pages 4 and 5 for more details. Check all packaging, box corners and flaps for small items.

ASSEMBLE AND READY THE UNIT.

Assemble the front, middle and rear handles with the supplied screws. Do not overtighten. *Screws are usually found pre-mounted in the case.* Remove the factory shipped plastic over the screen. Install cut-to-fit screen protector (not included, customer supplied) on the screen if desired before use.

POWER UP AND TEST THE UNIT.

You will need to fully test the unit as soon as possible. Within 72 hours

Assemble the Handles

Screws may already be mounted in the machine. If not, they are in the accessory packaging.

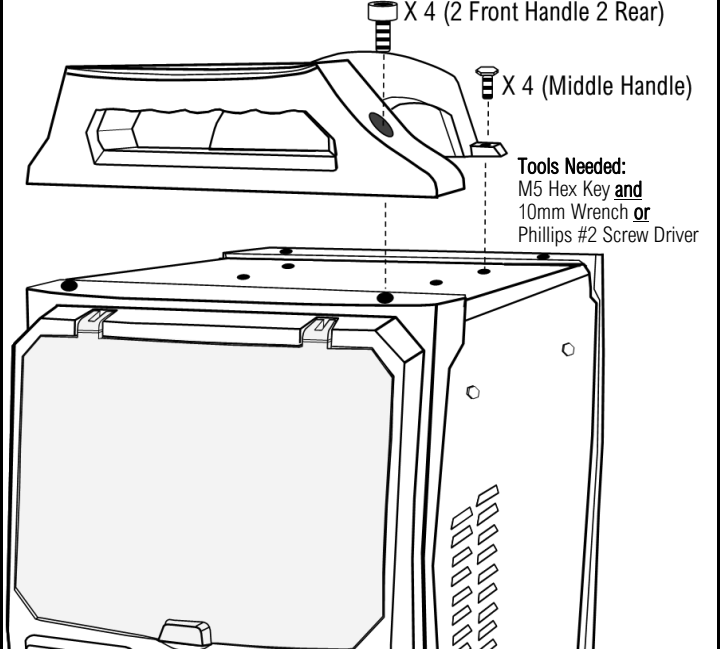

after delivery of the unit, be sure to have every thing you need at hand to test the unit. Make sure the correct input power, wiring, and plug configuration is being used. Then, power up your machine without any accessories installed. Allow the unit to idle for 15 minutes. Check and observe operation of knobs, controls and keys, cycling through each as required. *Make sure the fan is operating via the control panel menu setting.* After the test is completed, turn the unit off, connect the accessories, and shielding gas (customer supplied) to conduct live testing. Test all of the functions and features of the machine. For testing and welding, make sure the work clamp is connected directly to the part being welded (the work). Check for arc starting and stability. If problems are observed, contact Everlast for further guidance. See page 5 for more information.

NOTICE: *Cosmetic damage claims made after 30 days will not be accepted, unless Everlast is contacted and informed of such delay and reason for such a required delay (i.e. Overseas deployment or sudden disability).*

CHECK FOR GAS LEAKS.

Be sure to check for gas leaks before attempting to weld. You can test this by first installing both back caps into the torch head (from both sides). Next, remove the gas plug on the rear (save for storage use) and install the regulator. Tighten fittings on both cylinder and unit (see section on regulator installation). After the regulator is secured, set post flow time to maximum. Trigger a false start with either the foot pedal or torch switch by tapping and releasing so that post flow can flow. Observe the ball on the regulator. It will briefly float before settling back down. If the ball continues to flow, or if you hear or suspect leaks, use warm, soapy water (or a dedicated leak testing solution available from welding suppliers) and spray on all connections, including the torch connections at the head, and back cap.

Setup Guide

Getting Started

Don't forget to check the connections underneath the torch handle. If any leaks are present, bubbles will form around the area of the leak. Tighten any clamps or fittings found to be leaking. If the problem cannot be remedied, contact Everlast.

DISTANCE YOUR WELDER FROM YOUR WORK.

As a best practice technique, be sure to locate the welder away from the immediate welding area. The fan found in your unit is powerful enough to create strong air turbulence in the weld area. When the fan cycles on, it can disrupt the smooth, even flow of shielding gas around your weld creating unstable arcs and porous welds, resulting in dull finished weld. If possible the welder should be located at least 6 feet away from the weld area and should be placed on a different level to prevent weld porosity and defects being created by the welder's fan system. *Even though this unit offers both thermal controlled as-needed or demanded fan settings, fans operate at full revolutions when they are triggered into operation.* **Keep in mind that air flow exits from both the front and the sides of the welder.**

GIVE YOUR WELDER SPACE TO COOL.

The welder needs room to cool itself. Place the unit in a place that will allow 18" from all sides to allow for proper cooling. The welder pulls air from the rear, and pushes it through the unit's heat sinks to cool the electronics. The air is then exhausted through the front panel and side louvers of the unit. If any of sides is blocked or restricted, the duty cycle will be reduced, and overheating will occur, leading to possible damage if the restriction is severe enough. If you build a cart, never attempt to close off one side or the back completely. The Everlast Power Cart 330 and the NOVA Cart 375 LF have ample room for cooling built into the design of the cart. Never attempt to restrict air flow by attaching filters to the vents or altering the vents in any way.

Allow Air Flow Space of at least 18"

Keep a distance of 18" from all sides to promote cooling and preserve duty cycle. Less air space will reduce duty cycle, accelerate overheating and possibly decrease the service life of the welder.

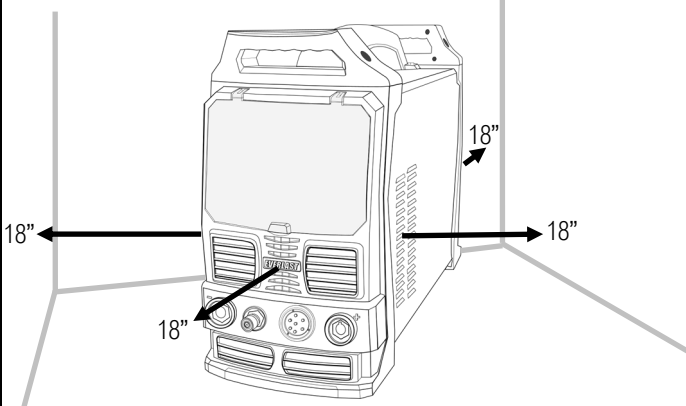

USING A WATER-COOLER WITH THIS UNIT.

Even though it is optional, as 330A welder a water-cooler is practically

require for use with this welder. Even though a 9 series 125A air-cooled torch is supplied with the welder, the unit should still be coupled to a water cooler and water-cooled torch for most welding. Even the largest air-cooled torch, the 26 series, is limited to only 200A for extended welding. Additionally, many people find that a water cooled torch connected to a water cooler significantly improves comfort level while welding. *The water-cooler connects directly to the torch, circulating water up through the handle and into the head before returning back through the power cable to the cooler.* This unit is equipped with a special 240V plug on the rear that is designed and intended for use with Everlast-brand water coolers. The Typhoon is designed and ready for use with the Everlast PowerCool 375. It is designed to fit and stack directly under the welder. By interlocking with the welder, the cooler can be semi-permanently mounted under the welder. Further details on connection of the welder to the cooler can be found in the PowerCool 375 manual and can be downloaded from the website.

The Typhoon features a "cooler-on-demand" feature which can be accessed in the background menu. It can be selected to be continuously on, to be active only when the arc is struck, or to be temperature controlled. *See information on page 31 to access this feature.*

NOTICE: The PowerCool 300 and 400 coolers may be used with this unit. However, they cannot be stacked under the welder. They will have to be used detached from the unit.

IMPORTANT: Make sure the cooler pump is primed before initial use, after extended storage or after torch has been disconnected and reconnected. *See PowerCool 375 manual for details about priming the pump.*

Stacking the Cooler

The optional water cooler package provides the necessary connection components to stack and mount it semi-permanently to the welder.

To mount the welder to the cooler:

- Install cooler mounting hardware onto the welder.
- Line up the interlocking grooves on the welder with the grooves on the cooler. Place the welder on the cooler.
- Slide the welder towards the rear of the cooler until the grooves are fully seated and the edge of the cooler bezel is flush with the welder.
- Install side mounting screws if a semi-permanent connection is desired.

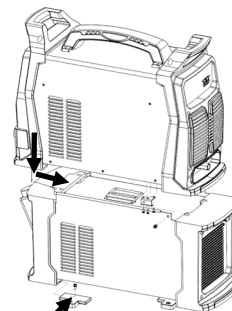

Use with PowerCart 330 Only.

Setup Guide

Getting Started

CONNECT YOUR UNIT TO THE OUTLET.

NOTICE:

There are special rules centered around wiring an outlet for service with a welding machine. The National Electric Code under Article 630 has developed specific regulations for wiring electrical service for welding equipment. These are different than for other types of service such as a stove or dryer in a household or even in a commercial application. You need to consult and/or employ a locally licensed electrician before installing this unit to make sure all national and local codes are followed. If you are not qualified to make these connections, don't. Everlast is in no way liable for any damages caused by improper connection of your welder. Your welder should be on a dedicated branch circuit not far from an electrical disconnect box. Importantly, it should not share circuits with other shop or household items. Do not attempt to adapt existing household circuits because conductor wire colors are different for welders. Additionally, only 3 wires are used for single phase welders. No neutral is used in a welder circuit. The white wire is a conductor in a single phase welder service. The red wire is not used. *The input power cable conforms to North American standards for size, length, with consideration given to inrush amperage, rated amperage and duty cycle. Do not modify, or attempt to rewire your unit. This will void your warranty.*

Wire Configuration 1 Phase 240V

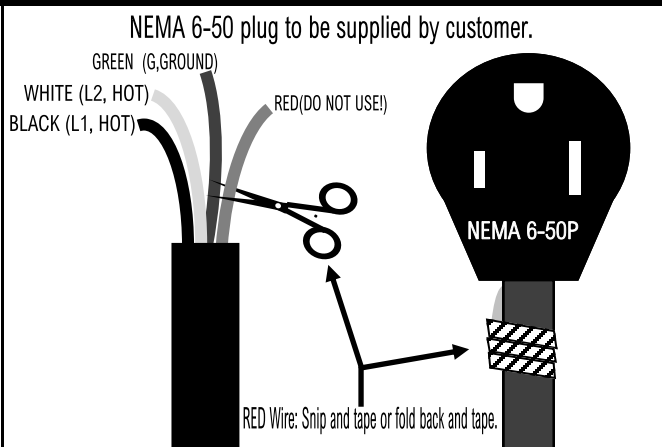

You will notice that the welder has been shipped without a power plug. This is because the welder will operate on either single phase or three phase 240V voltage and the wiring is different for single phase service than it is for three phase service. There is no one plug for all voltages and phases. You will also notice that this unit is equipped with 4 wires. The full 4 wire configuration is not used with single phase 240V operation. Only 3 wires are used (black, white, and green in color). The remaining fourth wire (red color) is to either to be snipped off and taped over with electrical tape, or it is to be bent back, and taped against the cable sheathing if it is to be used both on single and three phase service. For single phase 240V

connection, select a NEMA 6-50 Plug and Receptacle for installation. This is the standard plug used when wiring welders for 240V single phase operation in North America. (Other regions/countries vary). **A neutral is not used or required with a single phase welder.** If you inspect the NEMA 6-50 Plug closely, you will see that the plug is stamped where each color wire should go (most brands). If you do not see a stamp, the Black wire serves as L1(Hot), White serves as L2 (Hot) and Green serves as G (Ground). A common mistake is to use all four wires with a NEMA 14-50 outlet. This can damage your machine and cause improper operation.

For three phase 240V service (or for the optional 480V service), the plug type and NEMA classification is different for various applications. It is recommended to either install the line direct into an electrical cutoff box, or wire a 3 phase receptacle and cutoff (disconnect) close to where the unit will be in use. When wiring 3 phase, all wires will be used. Black is L1. White is L2. The Red wire should be reserved for L3, especially if you have a Delta 3 phase system. The Green wire is used for Ground.

Wire Configuration 3 Phase 240/480V

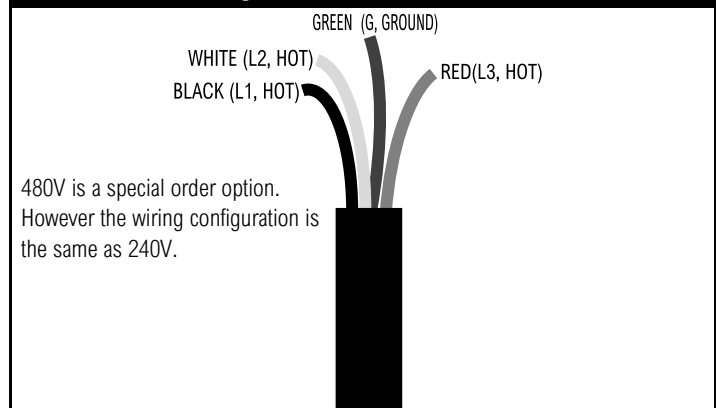

Selecting A Breaker and Wire Size

Select a breaker based off of the I1MAX rating of this unit. This is the maximum inrush current of the unit. The inrush is not a sustained current. The I1EFF rating of the unit is the maximum "rated" current of the machine. When combined with the length of the run from the main panel, this determines the conductor size needed to supply the welder, Refer your electrician to Article 630 and the specification page of this manual (or the specification grid printed on your unit) when selecting the correct breaker and wire size. Use a delayed trip breaker, or slow blow fuse.

Using with 208V 1 or 3 Phase

This unit may be operated with 208V service (1 or 3 phase). However voltage should be checked under load before allowing permanent installation. Voltage should not fall below 200V or damage may occur to the unit. Most modern 208V service runs several volts above 208V and is not usually a concern. Older installations where service wiring may be degraded or not up to code may produce sub standard or low voltage not suitable for use with this unit.

Setup Guide

Getting Started

CONNECT YOUR UNIT TO THE SHIELDING GAS.

What Shielding Gas Should Be Used?

Selecting shielding gas for TIG welding is straightforward. **In general, for all metals, whether using in AC or DC, select 100% Argon.** Never use a gas mix mixed with CO₂. CO₂ will rapidly consume the tungsten and introduce porosity into the weld, even at low concentrations.

With that said, if you are welding at or near the maximum capability of the unit, you may also wish to use an Argon/Helium mix. This will increase the overall heat going into the weld. Use no more than 25% Helium mix with this unit, or Arc starting efficiency will be reduced, resulting in hard-to-start arcs. Arc stability will also be affected at higher mix percentages. Helium is expensive. The cost versus benefit of adding it must be weighed carefully as a cylinder or two of high percentage Helium may approach the cost difference of upgrading to a larger unit! If a high Helium content mix is used, expect some trade-offs. Arc starting may be improved slightly by readjusting the arc starting parameters in the background menu of this welder.

There are a few new gas mixes (blends) on the market with promise, but as of publication they have not been thoroughly evaluated for use with this welder. Exercise caution when using a new mixture (often marketed with Nitrogen or Hydrogen) as the application is very specific. **Pure 100% Argon is the most economical and best choice for nearly every application. Having multiple gases should not be a concern for even the most advanced users.**

NOTICE: It is increasingly common for users to get cylinders of bad or contaminated shielding gas, creating mysterious and difficult to identify issues. An Argon cylinder is the same type of cylinder as an Argon/CO₂ cylinder used for MIG and sometimes times can get mixed in and relabeled as pure argon. Another increasingly common issue is that a gas mix cylinder gets refilled with Argon with residual Ar/CO₂ mix without using proper purging techniques. Usually this occurs in batches and complete lots of cylinders can be affected. Sometimes swapping with another cylinder from the same supplier will not correct the problem. Another common issue is that a customer may specify "Argon" and receive a cylinder marked as Argon/CO₂ mix from the distributor without noticing. *Check your cylinder label below the cap area for proper labeling before you accept the gas cylinder.*

Always wear safety glasses when changing a cylinder. Before installing the regulator, stand to the side of the cylinder valve, away from the discharge, and give a quick blast of Argon gas by slightly opening and closing the valve rapidly. This will dislodge any dirt or particles stuck in the valve or the threads. This will help reduce the chance of dirt particles making its way into the solenoid valve, causing future sticking and failure issues.

Connecting your cylinder will require a cylinder wrench (1 1/16") to connect the regulator to the cylinder (North American Cylinders with CGA 580

valve). If you do not have a cylinder wrench, a large adjustable-type wrench will work. However, make sure it is properly adjusted to prevent rounding of the shoulders of the fitting. Do not use pliers, or a serrated jaw wrench such as a pipe wrench to tighten the fitting.

Connect the regulator tubing to the regulator. The regulator tubing may have either a hose barb connection or a threaded connection (for North American markets). If the regulator supplied has a hose barb, make sure the hose barb fitting is tight on the regulator. Tighten with a 3/4" (19mm) wrench. **If it is a threaded connection, use two 3/4" (19mm) wrenches to hold both the regulator and the tubing connection at the same time.** Hold counter pressure on the regulator connector while tightening the hose fitting to prevent damage to the regulator and to ensure maximum sealing. After connecting the tubing to the regulator, connect the other end of the tubing to the 5/8" CGA fitting on the unit. **Hold the fitting on the unit with one 3/4" (19mm) wrench firmly while tightening the hose fitting with another 3/4" (19mm) wrench.** Other markets outside of North America may feature a hose barb connection in the rear. **IMPORTANT: This is a compression fitting!** Do not use thread tape or pipe sealant on any cylinder, regulator or other unit connection. The residue and debris may get into the gas solenoid and cause operational issues.

REMEMBER: Do not tighten the rear unit connection without holding the female fitting on the unit side with another wrench. If you fail to do so, damage is likely occur to the bezel and the female fitting as the fitting may turn in the plastic housing. Overtightening will cause the fitting to snap-off in the solenoid housing or crack down the threads.

Connect Regulator To Cylinder And Unit.

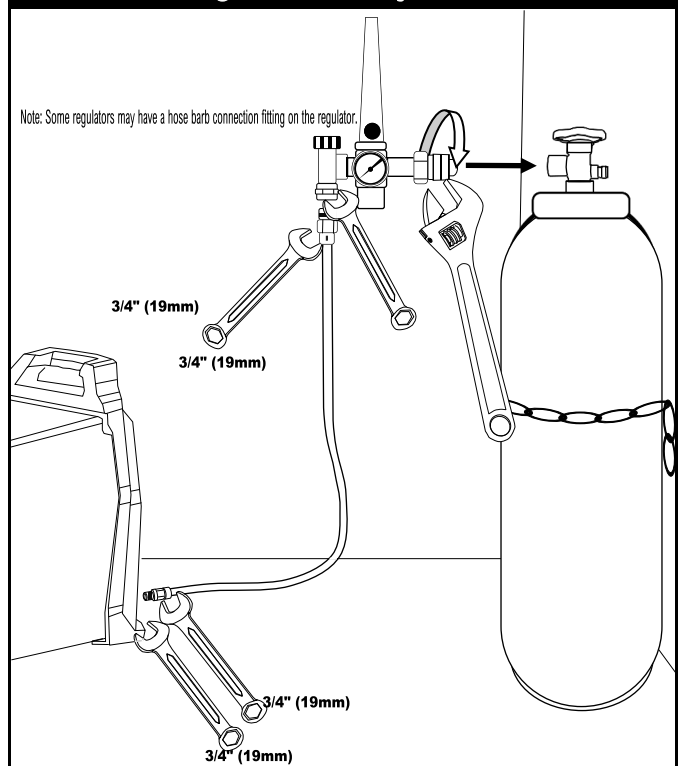

Setup Guide

Getting Started

SELECT THE PROPER TUNGSTEN TYPE.

What Type of Tungsten Do I Use?

Selecting the correct tungsten for your welder is important. Modern inverters no longer use pure (green band) Tungsten for welding AC. In fact pure Tungsten used with an inverter can create problems with arc stability, arc starting and excessive balling. While Thoriated 2% Tungsten can be used in an inverter for DC welding, and even for AC welding, it is falling out of favor in the industry due to the slightly radioactive nature of it. It also presents some additional issues while welding with nodules and splitting at the higher Amp range in AC.

For welding in AC and DC consider the following types.

- Lanthanated 2% (blue band). Overall this is one of the best choices for TIG welding and can be used for AC and DC welding. It has great arc starting characteristics, with excellent point holding capability.
- Ceriated 2% (gray band or orange band, depending upon brand and country of origin). This is a good choice for welding with both AC and DC. However, it doesn't hold up as well and starts to erode faster than Lanthanated at higher amperages. Arc starting quality is excellent.
- Lanthanated 1.5% (gold band). Holds up nearly as well as Lanthanated 2% and can be used for AC or DC welding. In some tests it has rivaled the performance of Lanthanated 2%.
- Tri-Mix/Rare Earth (purple, turquoise or other color band). While still relatively new, it is being marketed as a replacement for Thoriated 2%. Overall, it does perform fairly well and even excels in many circumstances. But some problems have been seen with quality control and inconsistency in performance. The primary metal oxide used is lanthanum 1.5%. Usually it also includes a small percent of Zirconium and Cerium to complete the mix. Some use Yttrium. But the balance of the components in the blend are usually stated to be around .06 to .08%, but can be allowed to vary up or down from .04% to .9%, making the blend prone to inconsistency in quality control.
- Thoriated 2% (red band) Still considered the best for DC, works ok for AC, but has been banned in many markets outside the US due to a small radiation risk posed as an alpha emitter.

Do not use the following types of Tungsten.

- Pure Tungsten (green band). This will create arc instability. The tungsten will not stand up well to the more intense arc created by an inverter welder.
- Zirconiated Tungsten (white band). This was created as an alternative for pure Tungsten for transformer welders. Similar issues welding issues are presented as with pure Tungsten.

Purchasing Tungsten can be difficult. Local suppliers tend to put a premium price on Tungsten, and may be three times an online price direct from a distributor. In many areas, the choice of tungsten may be limited. However, many local welding suppliers are stepping up and offering competitive prices and range of selection, so don't rule them out until you have checked. Also, there are some companies that may send you free samples to test, so be sure to investigate their product, and give them a chance as well.

GRIND THE TUNGSTEN CORRECTLY.

An improperly ground point on tungsten is a cause of many issues with arc stability, arc directability, and penetration. A bench grinder and a fine-grit stone dedicated for tungsten sharpening is all you need to sharpen Tungsten and is the age old standard. There are special hand held grinders that feature diamond stones with slotted guides, designed to hold the tungsten at the exact desired angles. A dry chemical sharpener "dip" is available and is inexpensive. When properly swirled, it does an excellent job in seconds. With practice, it can deliver a superior result. As a bonus feature, chemical sharpening can be done without getting up from the bench-top without removing the tungsten from the cup. One thing to note: the Tungsten has to be red hot before being dipped and swirled in the chemical.

! WARNING!

Wear safety glasses and leather gloves while grinding tungsten or serious injury may occur. On occasion tungsten may split or shatter. Do not breathe or inhale tungsten dust. **Do not use an angle grinder to grind!**

How Do I Grind My Tungsten On a Wheel?

- Grip the Tungsten firmly. Grind with the Tungsten secured.
- Grind the Tungsten perpendicular to the wheel face. Allow tungsten to grind slowly without much pressure.
- Rotate the Tungsten quickly as it is being ground to keep the point even and symmetrical.
- Do not grind the Tungsten parallel to the wheel face or an unstable arc will result.

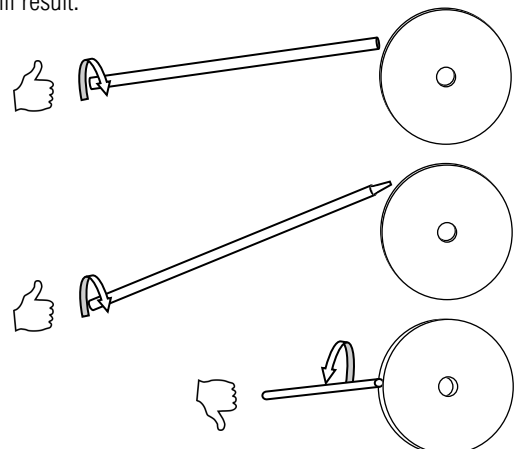

Setup Guide

Getting Started

Choosing the proper grind angle is important to achieving the weld penetration, bead appearance, and arc-cone width that you desire. While there is no true one-size-fits-all angle, there are some general rules of thumb to observe and follow:

- Always grind in-line with the length of the tungsten. Never make a radial grind that leaves marks on the tungsten in the direction of the grind. Radial marks will cause arc instability. Never grind with the tungsten held parallel to the stone edge face.
- For most applications, grind a point that is 2 –2.5 times greater in length than the tungsten is wide. This will create an angle of about 30° to 35°.
- For AC, a more blunt angle may be used (around a 60°) for best penetration. However, the 2 to 3 times in length rule will still work for many circumstances.
- For higher amperages, you will want to put a slightly truncated tip on the tungsten. This prevents the tip from dropping into the metal.
- Grip the tungsten firmly. Slowly rotate it while grinding.

What Type of Grind Works Best?

- Never use a radial grind pattern. This can be caused by grinding at the wrong angle, or spinning the tungsten too fast while grinding at the proper angle. The arc will be unstable.

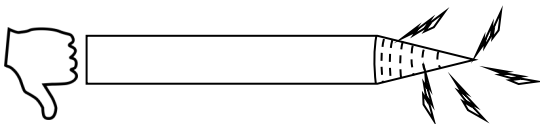

- Grind the angle so that the length of the grind measures 2 to 2.5 times the wide of the tungsten (For general purpose use this should form about a 30° to 35° angle.) A slightly blunted end (truncated) may be used if the amperage is over 50A to prevent the tungsten from breaking off into the metal while welding.

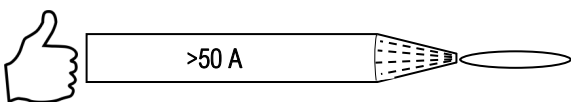
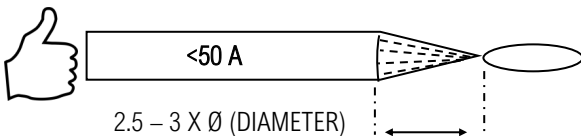

- AC welding may require a blunter point for some applications where greater penetration is desired. It may seem counter-intuitive, but this will create a narrower arc cone and provide more penetration.

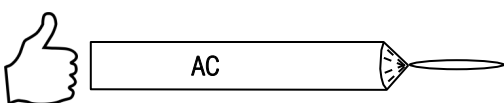

Depending upon what arc properties you are looking for, you may periodically want to regrind your tungsten to maintain optimal arc characteristics.

IMPORTANT! Don't Ball The Tungsten.

If you've ever operated an older transformer welder, or an early inverter type TIG welder, you were probably taught to ball the Tungsten when welding on AC. In fact, a lot of well meaning literature still exists about proper tungsten ball size, how to ball tungsten, etc. Even now, well-meaning instructors and seasoned welders (who have never worked with an inverter) may even insist this is the way to weld.

However, this is no longer true or recommended with an inverter TIG welder. In fact, if you insist on balling tungsten while welding with an inverter, you are going to create an unstable, uncontrollable arc. You will then have to make unwise adjustments to the machine to create more stability. Be warned. Don't blame the machine. Blame the ball.

Why? The old "Green" Tungsten is considered to be pure Tungsten. This means that it does not handle heat as well at higher temperatures as the more modern tungsten types that are blended with rare earth metal oxides. Green Tungsten will create a significant ball on its own when it is used with an inverter. In the past it was needed to hold a certain type of arc cone and was desirable. In inverters, it will lead to arc wandering.

Due to the nature of the AC cycle and modern advancements in control, modern inverters with advanced wave forms really punishes pure Tungsten. You'll quickly end up with a large, molten ball dangling at the end of the tungsten. This is, in part, due to the short off-time between polarity change from + to - and back to + during the AC cycle. In fact, this off-time is so short that inverters do not need High Frequency Stabilization (HF) while welding AC, and do not have it. In fact HF is only used for establishing the arc. After Arc establishment, the HF shuts off automatically. The extra "time-on" of the arc means that pure tungsten (green) isn't able to handle the heat and will over-ball and melt quickly. Rare-earth blends of Tungsten are used for that reason and will handle the heat and punishment better. If given enough heat at the high end of the operating range of a specific sized diameter, the rare earth types form a neat bullet-shaped dome that is slightly elongated. However, this dome still isn't quite yet a full, rounded ball.

If you think about it, the big ball at the end is really a large "target" for the arc to jump to as it reverses polarity. When the electrons begin to flow from the plate to the tungsten, that is a bigger target for the electrons to hit. The arc could literally jump anywhere along that ballled surface. The bigger the ballled target, the more room for the arc to oscillate around the ball, creating a randomly wandering arc. This is why pointed Tungsten is recommended with inverters.

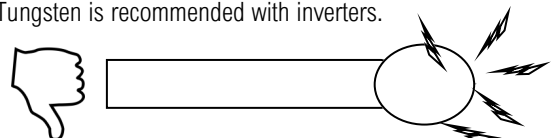

Setup Guide

Getting Started

SELECT THE PROPER TUNGSTEN SIZE AND START AMPS.

The key to obtaining good, picture-perfect arc starts is to use properly sized and ground Tungsten. A properly sized Tungsten, combined with correct sharpening technique will display the best arc characteristics. An undersized tungsten will tend to ball at higher amperages, especially if the tip is too sharp for the application. A larger Tungsten will be more difficult to start at lower amps, regardless of grind shape. A contaminated Tungsten, will cause no-starts, irregular starts, and wandering arcs.

The design of this unit limits the low Amp start of the welder based off the Tungsten diameter size selected on the screen. This Start Amperage is independent of the normal Welding Amps and even the tail-out (End Amperage) settings. In fact, the Welding Amps and the End Amps are actually able to be set lower than the Start Amp setting (when not in the "Manual" mode). The intent of this limitation is to create an optimized "surge" start parameter for the Tungsten selected so that it starts quickly and reliably with average user skill and knowledge. It is not designed to provide the lowest possible Amperage start for the selected Tungsten size. Each increase in Tungsten diameter raises the minimum allowed Start Amp setting. The range of diameter in Tungsten sizes that are selectable under the Tungsten function, are .040" (1.0mm), 1/16" (1.6mm), 3/32" (2.4mm), and 1/8" (3.2mm).

In addition to the selectable Tungsten size function, the machine includes a "Manual" setting in the Tungsten size function to override the low Amp limits and allow a full range of Amperage. The "Manual" selection should be used to allow the full range of Starting Amperage if customer is using a small .020" (.5mm) diameter Tungsten. It may also be used with a larger diameter Tungsten if the user desires complete control over the start Amperage. Selecting the "Manual" setting allows the unit to be set at a minimum TIG start of 2 Amps on DC and 3 Amps on AC. Keep in mind this may not provide optimal start characteristics for larger diameter Tungsten but it does allow the user to try. Manipulating the Start/Surge settings of the electronic HF/HV settings in the background menu may improve the low Amp starts with larger diameter Tungsten sizes as well. However, it may also increase the chance of blow-through on thin materials by providing too forceful of a start.

What Size Tungsten Do I Use?

Everlast advertises low arc start capability on this. The Start Amperage of the arc is quite low. However, when starting an arc, all TIG welders have a momentary surge Amperage to ignite the arc, lasting just milliseconds. This brief surge (up to 40 or 50 Amps) of Ignition Amperage is usually kept from displaying in most brands of TIG welders. This very quick surge ensures good arc starting. However, if the surge it is set too high, it can blow through thin materials before the arc is established and the unit transitions to the Start Amp setting. Everlast has kept the Ignition Amps surge to a range that has tested best for clean starting. However, when welding with thicker tungsten like 1/8", arc starts may appear "soft" and not forceful enough to start cleanly. If the arc starting is not smooth or quick, the surge Amperage can be raised or the intensity of the HF electronic start can be adjusted in the background menu. This will help to clean up and improve the arc start. **NOTICE: The Surge Amps and the Start Amps are not the same thing. Starting Amperage is the stage after the arc transitions from the Ignition surge and stabilizes.**

For best results, when low amp starts are needed for welding thin gauge materials, use a 1/16" diameter Tungsten for most light gauge materials. For thin materials under 20 gauge use a .040" diameter tungsten or even a .020" diameter tungsten for maximum control. Arc starts will then be clean and crisp on thin materials. Keep in mind though that small diameter tungsten will rapidly consume at higher Amperages.

The tungsten type, tip angle and grind preparation will ultimately affect amperage carrying and arc starting capability of the tungsten. The machine wave form and other AC settings can also affect it. Each type of Tungsten blend will also vary in amperage handling capability. In general, consider the following for selecting your tungsten diameter. The list below is not the absolute maximum range of the Tungsten, but a reliable recommended range. It is a good practice when you approach the maximum limit of the Tungsten's capability in terms of amperage, that you switch to the next size up for best point retention and arc characteristics.

AC operation can reduce tungsten amperage capability. The setting of the AC balance and AC frequency has an effect on tungsten point holding capability. Too much cleaning (over 40% EP) will over heat the tungsten and ball it. Lower frequencies tend to places more heat on the tungsten as well. But in general, for AC and DC operation, consider using the following sizes for the ranges following:

- 2-15A: .020" (.5mm)
- 3-30A: 40" (1mm)
- 10-70A: 1/16" (1.6mm)
- 15-200A: 3/32" (2.4mm)
- 20-300+ A 1/8" (3.2mm) 20-300+A

NOTE: Starter kit does not include .020" (.5mm) or .040" (1mm) collets or collet bodies. These can be purchased locally or online.

Setup Guide

Getting Started

TIG BASIC STARTING POINTS.

This machine makes use of the Synergic PowerSet feature. However, If you are needing basic help getting started with manual settings, without using the PowerSet mode, here are some general settings and selections to get you started TIG welding. This guide is intended to be only a starting point, not a completely exhaustive source. Keep in mind that no guide is a substitute for practice and experience. You may find that your final settings may be different from the ones listed. **The following guide does not represent the maximum capability, or even the recommended capability of the unit.** However, it demonstrates what is considered to be a practical capability limit of multiple variables when factored together. It is possible to weld thicker materials with the same amp range. However, as a best practice, the industry does not recommend heavy passes, rather thinner

“stacked” passes on thicker plate. Multi-pass welds are typically stronger, have less defects and require less amperage. On heavy gauge plate, such as 3/8” up to 3 to 5 passes may be required. Additionally beveling of the joint is required for complete joint penetration, even at higher amperages. The thickness rating takes into account the “heat sink” capability of the metal, and the power of the amperage to overcome the conductivity of heat of the metal used using multiple passes. The position of the weld also influences the amperage, cup size, gas flow rate and tungsten size used. For the following recommendations, these are all in “flat” position. Modify your settings accordingly. Vertical will require less amperage the more you weld “up hill”.

NOTE: For perspective and comparison, the chart below includes some information that is beyond the operating range of this welder.

Amp Range	Metal Thickness Aluminum (AC)	Metal Thickness Steel/ Stainless (DC)	Electrode Dia.	Cup Number	Flow Rate (CFH) Standard Lens	Flow Rate (CFH) Std. Gas Lens		
2-15A	<.020”	<.025”	.020” (.5mm)	4	5 to 7	4 to 5		
3-30A	.005” to .030”	.003” to .035”	.040 (1.0 mm)	4 or 5	5 to 7	4 to 5		
5-70A	.005” to .0612”	.005” to .093”	1/16 (1.6mm)	4, 5, 6	6 to 15	6		
10-200A	.010” to .250”	.08” to .375”	3/32” (2.4mm)	5,6, 7 or 8	10 to 20	8 to 12		
20-250A	.020” to .375”	.015” to .500”	1/8” (3.2mm)	6,7,8 or 10	15 to 25	10 to 18		
50A-350A	.050 to .625”	.050” to .750”	5/32 (4mm)	8-10	20-40	15-35		
Cup Size	4	5	6	7	8	10	11	12
Inside Diameter	1/4”	5/16”	3/8”	7/16”	1/2”	5/8”	11/16”	3/4”

IMPORTANT!

This unit is designed to operate with most welding rods including E6010. This unit should operate well with E6011, E7010, and E8010 as well on the E6010 setting. It should operate well with any other welding electrodes that have a deeper penetrating cellulose-based flux on the E6010 setting. When welding with cellulosic types, some brands may weld differently than others. Always select a good quality brand for best arc stability. If instability is observed, switch brands or change the rod suffix designation. This unit operates best with a short arc, so either drag the rod, or hold a very short arc length so that arc outages are not experienced. A dragging motion, or a slight weave is recommended, but increasing the arc length may result in arc outages. Rods like E7018, and E7014,308, 309L, 316 and hard surfacing rods are excellent choices for use with this machine.

STICK BASIC STARTING POINTS.

This unit also has a synergic PowerSet mode for stick. However, this may not suit all situations. This guide is a starting point for manual settings. Stick is a bit different from TIG in the fact that the Amp settings center

around the diameter of the electrode rather than that of the of the plate, although plate thickness and joint design can shade the amperage range higher or lower. Use beveled joints and multi-pass welds for best weld strength on plates greater than 3/16” thick.

Electrode Class	Electrode Diameter					
	3/32”	1/8”	5/32”	3/16”	7/32”	1/4”
E6010	40-80A	75-120A	110-165A	145-220A	175-250A	220-315A
E6011	40-80A	75-120A	110-165A	145-220A	175-250A	220-315A
E6013	50-85A	80-125A	110-175A	150-230A	220A-300A	250-325A
E7014	85-115A	110-160A	150-210A	195-275A	265-335A	325-400A
E7018	65-100A	90-160A	145-220A	195-275A	255-335A	325-400A
E7024	100-140A	140-185A	180-240A	240-300A	285-360A	340-430A
E308/309/316	40-70	50-95A	75-130A	95-160A	Not Common	Not Common

Setup Guide

Getting Started

SELECT THE PROPER TIG POLARITY AND CONNECTIONS.

Selecting the correct polarity for TIG is quite simple. Whether you are TIG welding in AC or DC, the TIG torch will always be connected to the negative (-) output terminal located on the left side of the welder. Once the TIG torch is in the negative terminal, it will never change as long as you are TIG welding. If you select the wrong TIG polarity, the Tungsten will be rapidly consumed. It will ball up and draw back to the collet body after only a few seconds when the arc is initiated. Also, because the HV/HF connection is to the negative terminal, the arc will typically be hard to start, since the HV/HF starting energy would be flowing the wrong way through the work clamp and torch. Of course, if the TIG torch is correctly connected, the work clamp will be connected to the positive (+) terminal located on the right side of the welder.

The TIG torch switch or the Foot Pedal is connected to the 7 pin control connector. This allows you to select 2T or 4T control with the torch switch OR foot pedal control.

KNOW THE DIFFERENCE BETWEEN AN AIR-COOLED AND WATER-COOLED TORCH.

Where Do I Connect The TIG Torch?

Air-Cooled TIG Torch (9 Series Included)

EN (-) for AC and DC

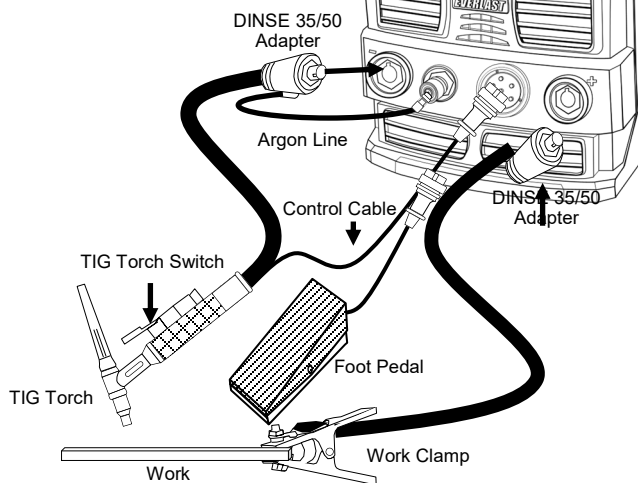

NOTICE: Choose between the torch switch operation (2T/4T) or the foot pedal operation. Both cannot be used at the same time.

An air-cooled and water-cooled torch connects differently. An air cooled torch for this unit will have one line exiting from the DINSE Connector. This is the gas/argon line. The water cooled torch will have 3 lines. Two descending from the torch, and one exiting from the DINSE type connector. Traditionally, the black line descending down from the torch will be the argon line. (Some brands vary

in return line. Follow the color coding used by NOVA.

GET A COOLER FOR THE WATER-COOLED TORCH.

Where Do I Connect The TIG Torch?

Water-Cooled TIG Torch (20 Series Included)

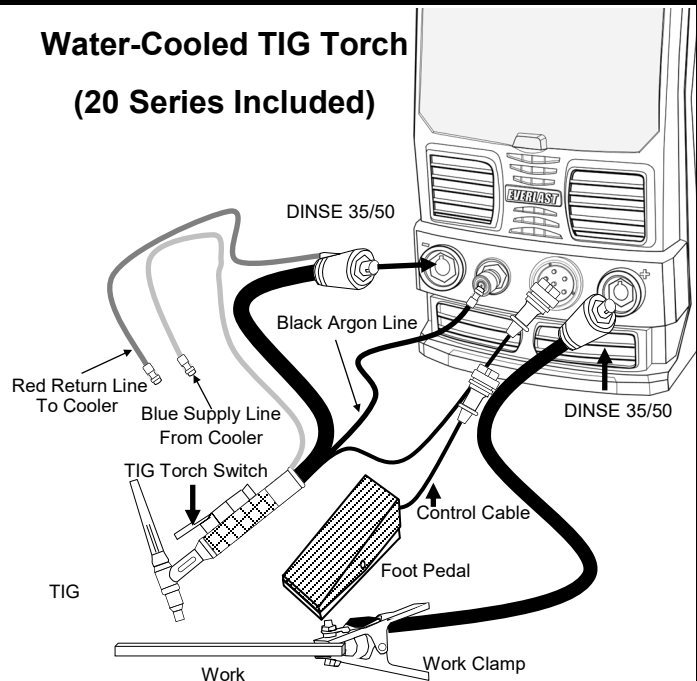

NOTICE: Choose between the torch switch operation (2T/4T) or

WARNING!

A water-cooled torch must be operated with a water-cooler or permanent damage will occur to the torch. Any operation without water can damage the torch. There is no safe amp limit for operation without water. If you have a water cooled torch and no cooler, you must order a cooler before you use the torch, or purchase a separate air-cooled torch. If an air cooled torch is purchased, observe the amp limits of the torch. For example, the 9 series air-cooled torch included is rated for DC use at 125 A @ 60% Duty Cycle. For AC use it is rated at 90A @ 60% duty. If welding is sustained much over the torch rating, you must purchase and use a water cooler and water-cooled torch. Torches operated without water, or sustained amperage over their rating and duty cycle, are not eligible for warranty replacement. Always match the torch to the job. Most users find that one torch is not enough and several torches may need to be purchased to suit different welding applications. Each torch size/class has different amp limitations. Know these limitations before using.

The Typhoon welder features improved provisions for the pairing of the welder and the water-cooler. The PowerCool 375 water cooler is designed to stack seamlessly under the welder. The panels of the welder and cooler

Setup Guide

Getting Started

interlock to provide a slip free connection. Additionally, the units can be locked semi-permanently together by installing the connecting screws with the bracket provided with the cooler. See the separate water-cooler manual for proper connection and pairing of the welder and cooler.

By accessing the background menu on this unit, the water-cooler can be selected to cycle on and off with the arc or can be selected to run full-time during heavy use. The cooler does not monitor or switch itself. The power supply to the water-cooler is cycled on and off by the welder.

SELECT THE PROPER STICK POLARITY.

The electrode holder, or stick torch (also commonly called a “Stinger”) will almost always be connected to the right positive terminal of the machine when welding in DC Mode. By default, the work clamp will then be connected to the negative. This is known as DCEP (DC, Electrode Positive), Although it is an older term, this is sometimes this is known as “reverse polarity.” Most all welding rods weld primarily in DCEP. There are a few rods like E6011 which can operate well with either polarity. Even so, the preferred polarity, is DCEP. Reasons for welding with DCEN are usually to provide a softer arc, or to reduce burn through with aggressive rods. Switching to straight polarity in DC mode will not harm the welder, but it may not produce reliable or sound welds.

In AC mode, due to the configuration of the welder output, the electrode holder (Stinger) should be connected to the negative terminal, the same as you would for TIG welding. This is because of the way the machine reads and adjusts the AC parameters when welding in stick mode. It is similar to TIG and uses electrode positive as a reference point. The display will re-

mind you to operate with the electrode holder in the Negative Terminal. Not all welding rods can create a satisfactory weld in AC mode. Welding rods such as E6011, E6013, and E7018 can be used and welded with in the AC mode. Depending upon brand, E7018 may not be recommended for AC use. However, most companies actually offer a specially formulated E7018-AC, which provides better arc striking in AC mode, and still can be used in DC if necessary. AC Stick mode will typically be used only when arc-blow becomes an issue and a stable DC arc cannot be maintained.

USE THIS AREA FOR MAKING OPERATION NOTES:

Where Do I Connect the Stinger for DC?

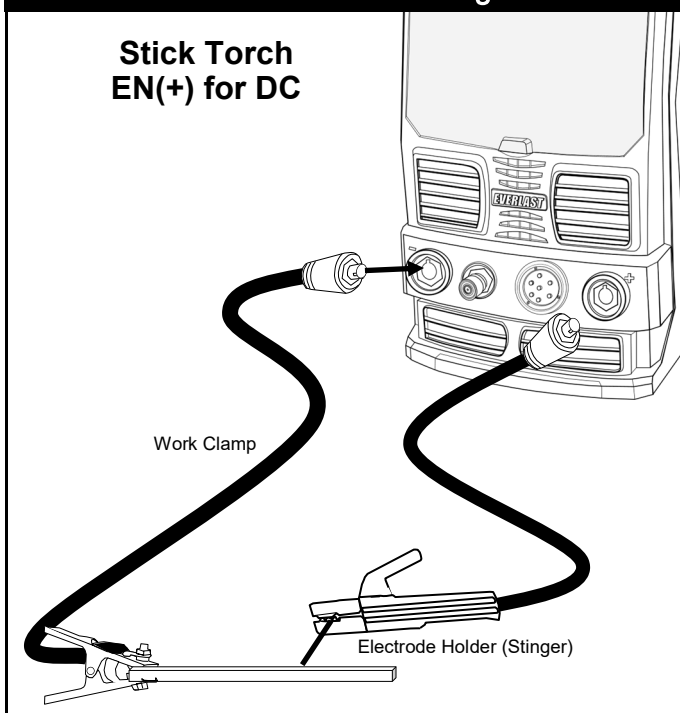

Where Do I Connect the Stinger for AC?

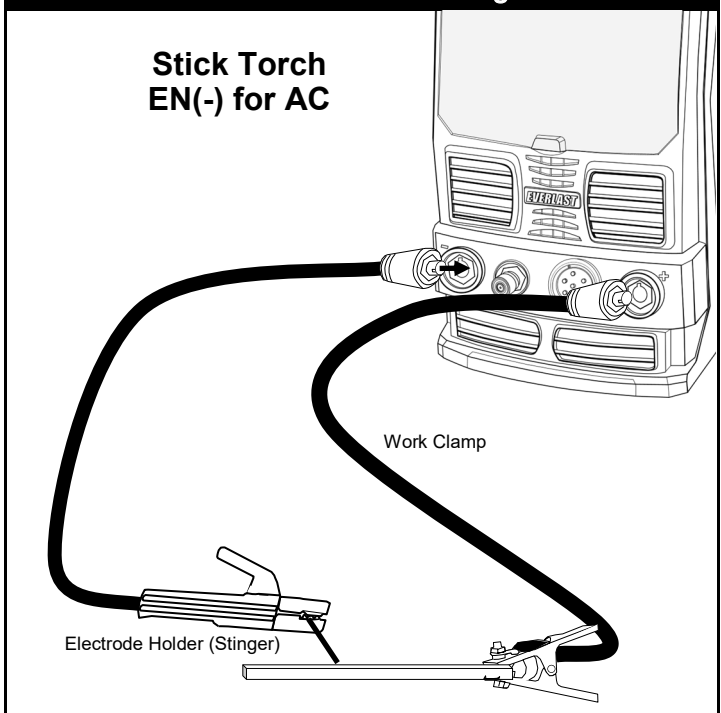

Component Identification and Explanation

Front Panel View

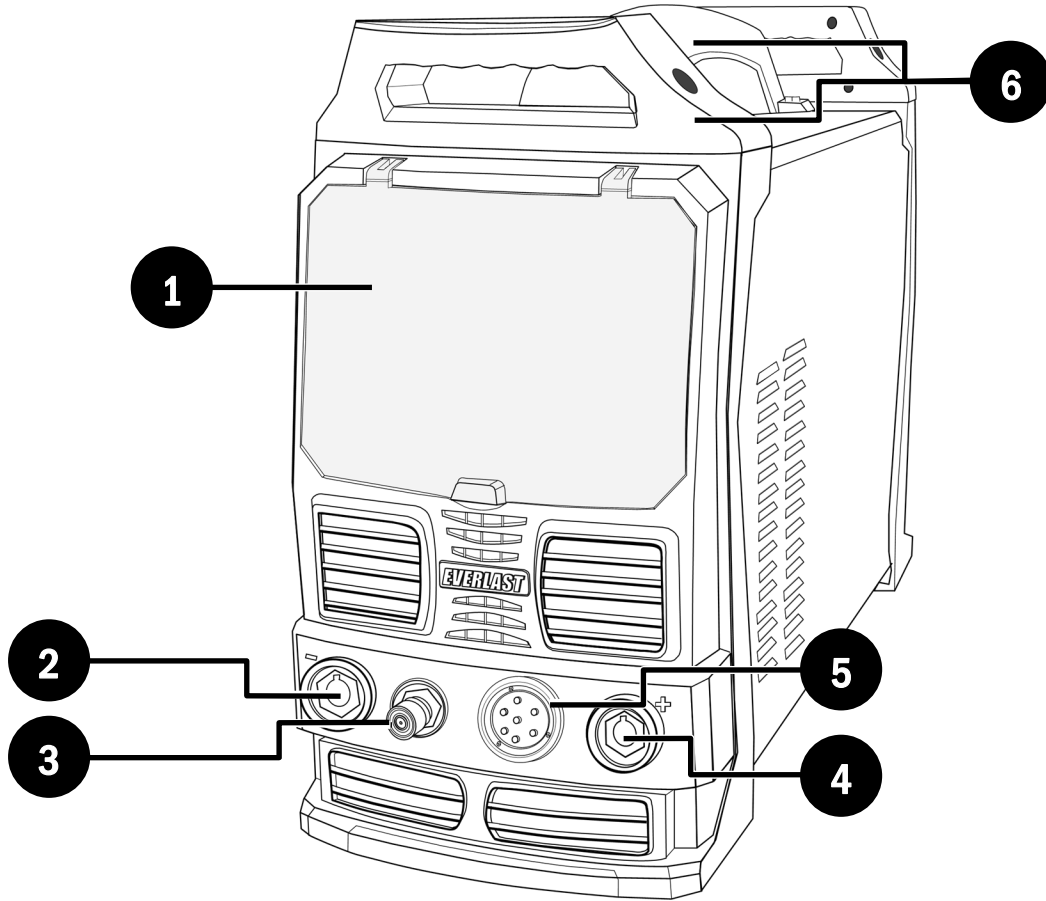

No.	Component Identification	Function/Component Note
1	Protective Cover	Keep down and in place during welding activities and while in storage.
2	Negative Terminal (-) (DINSE 35/50mm ² Type, 1/2" nominal dia.)	Connect the TIG torch to this terminal for all TIG welding applications including AC. Connect the work clamp to this terminal for most DC Stick welding applications. Connect Stick electrode holder (Stinger) to this terminal for AC Stick use.
3	Shielding Gas Connector (Quick Connect, 9mm tube Type 21)	Single Shut-off Type for Inert Gas. Ref. EV-9MM-B-QUICKCONNECT-STDSET or 21KATS09MPX
4	Positive Terminal (+) (DINSE 35/50mm ² Type, 1/2" nominal dia.)	Connect the work clamp to this terminal for all TIG welding applications including AC. Connect the Stick electrode holder (Stinger) to this terminal for most DC Stick welding applications. Connect the work clamp to this terminal for AC Stick use.
5	7 Pin Control Connector (5/8" Type GX16-7)	Ref. EV-PANA7-625-PLUG
6	Handles	Assy. Required, removeable for Low Clearance applications. Be sure to Reinstall screws in the cover and panel if the handles are removed or not installed.

Component Identification and Explanation

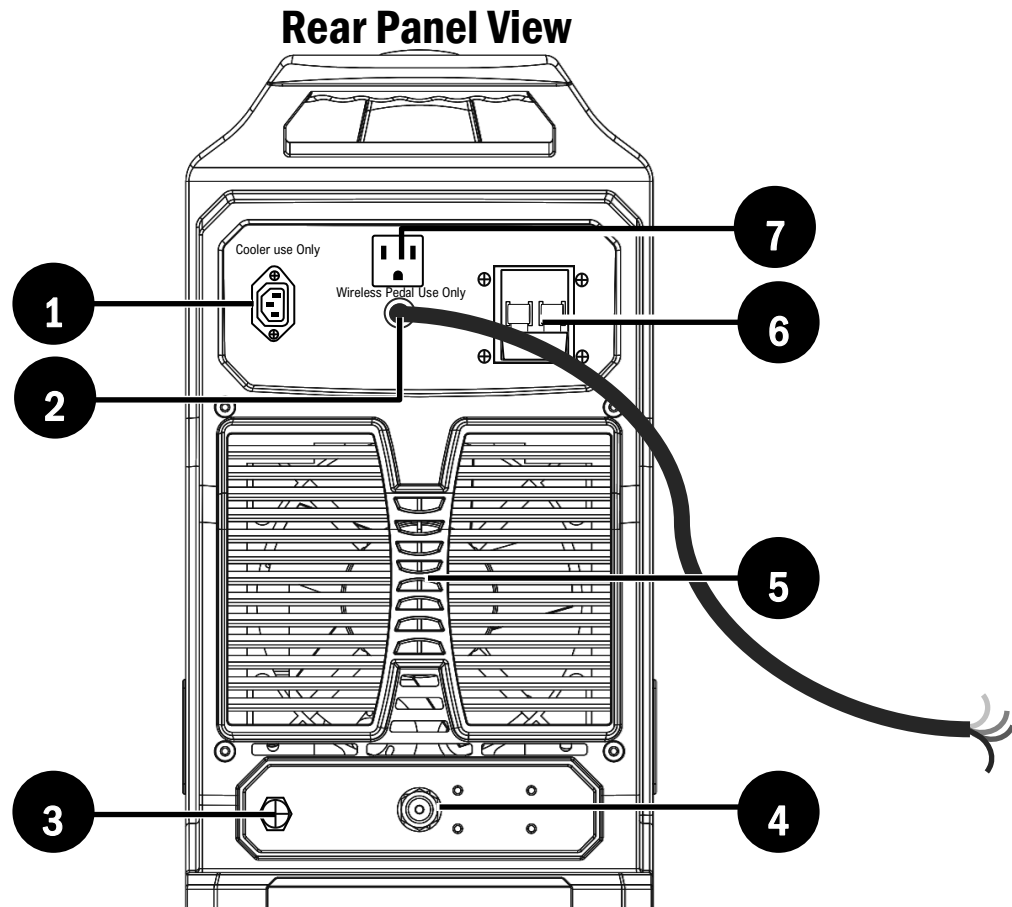

No.	Component Identification	Function/Component Note
1	Water Cooler Outlet (240V 1Ph, 4A max)	This outlet is to be used with Everlast 240V rated water coolers only. Do not use with any other application. Do not operate with single voltage 120V Everlast coolers.
2	Input Cable 6.5 ft. (No Plug)	North America only: The unit may be operated on either 208 or 240V 1 phase power. North American codes and standards dictate that only 3 wires are used for 240V 1 phase operation of welders. A neutral wire is not used nor recommended. For wiring a 1 phase connection to the unit: Use the Black wire for L1, the White wire for L2, and the Green wire is used for ground. The Red wire on the welder is not used while operating on a 240V 1 phase circuit. This is in accordance with North American code for welder wiring (see Article 630 of the NEC for more info). However, this presents a problem when wiring the welder for existing services where a red wire may be present in a 4 wire configuration that includes white as a Neutral or where older 3 wire systems may be present that use the red and black conductor wires for hot wires. A welder does not use a Neutral. The white and black wires are used as conductors for a 240V 1 phase welder circuit. If a red wire is used as a power supply conductor to the welder, then the black conductor wire should be matched to the black wire on the welder and the red conductor wire should be matched to the white wire on the welder. <i>The customer-supplied NEMA 6-50P is the proper plug used for wiring single phase 240V 1 phase welders in North America unless the welder is wired directly into a cut-off switch. Other regions may vary and may have a different plug type or no plug at all. Use with a dedicated outlet only. Do not share other circuits on the same breaker/fuse.</i> For 3 phase service, the Black wire is used as L1; the White wire is used as L2; and the Red Wire is used for L3. When possible, wire the welder directly into a cut-off box. Various acceptable styles of 3 phase plugs may be used, as long as the plug and receptacle are rated for 3 phase and meets the IIEFF rating of the welder.
3	HF Ground Service Bolt	This is to be used only if needed to mitigate any electrical interference that may be caused by the HF start or general operation of this unit. If disturbance in nearby electrical items such as lights and electronics is observed, this may be required. A 12 gauge copper wire should be connected to this terminal, and routed direct via the shortest route possible to a dedicated copper rod driven into moist ground outside the weld area. All metal items in the shop must be grounded to the outside at regular, multiple intervals, including any metal building panels. Consult a local licensed electrician to perform this connection if needed. If interference persists, after professional connection, or if your electrician has questions, contact Everlast Technical Support for further help.
4	Shielding Gas Inflow Connector (5/8" CGA)	North America: 5/8" CGA R.H. connector. Standard Argon/Inert gas type. Other Markets: Hose barb connection.
5	Fan location	Periodically check for proper fan function and cleanliness.
6	Breaker/Power Switch.	This switch doubles as the main power switch and disconnect switch. If this switch trips and the welder power turns off, a significant internal event or failure of the switch <i>may</i> have occurred. If this occurs, immediately remove from service and mark and tag as out-of-service according to required work regulations and contact Everlast Tech Support for further diagnosis and/or repair options.
7	Foot Pedal Power Outlet (240V 1 Ph 3A)	This outlet is an outlet that is intended for use with the NOVA wireless foot pedal designed for this unit only. This outlet is to be used to power the transmitter side of the pedal. NEVER use for any other application. This is a low Amperage service. Using this outlet with Tungsten grinders, angle grinders, and other devices other than the foot pedal outlet will cause damage, fire, electrocution and personal injury. The design of the outlet will output 240V.

Component Identification and Explanation

Control Panel Layout

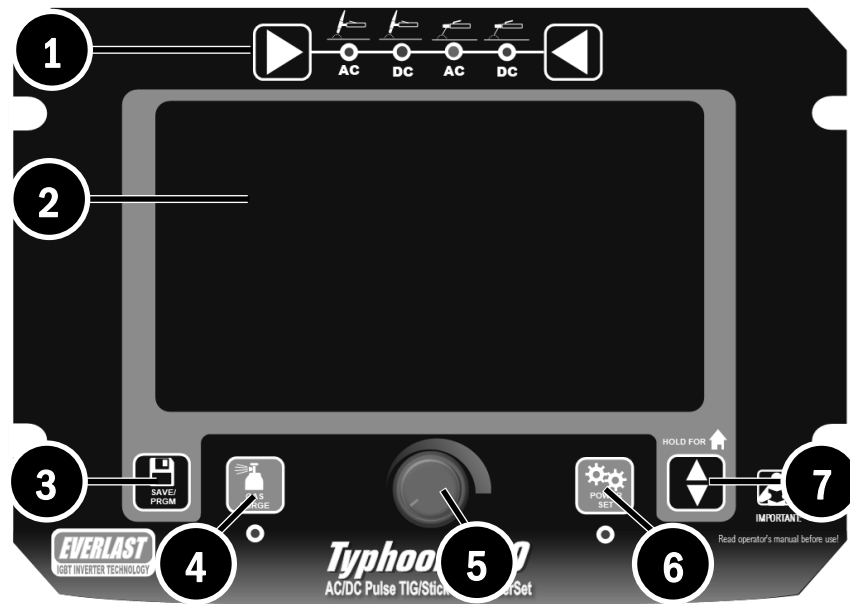

No.	Component Identification	Function/Component Note
1	Welding Process Selector	Press left or right arrow key to navigate back and forth to select the desired weld process. The LED will light to indicate which weld process has been selected. See Quick Setup Section.
2	5.1" 720HD TFT Color Display	This display is designed to be one of the clearest and brightest in the industry and will provide long life if proper care is taken. Keep flip down cover in place when not in use. Remove temporary, original protective film on the screen surface upon delivery. Use cut-to-fit screen protectors as a replacement for future use. Do not use harsh cleaners. Use only screen type cleaners sprayed onto a damp, lint free rag to clean. Remove dust with short bursts of dry compressed air.
3	Program Save Key	Use this key to both access the program menu and save it. See Quick Setup Section.
4	Gas Purge Key	This key is used to help facilitate gas flow setting. The LED will light when pressed and activated to serve as a reminder that the function is still active and gas is flowing.
5	Navigation and Adjustment Control Knob	This control knob serves two main functions. It is used to navigate and it is also used to adjust parameters. The actual way the knob functions is somewhat fluid as each menu screen is different. But in general, turn the knob to navigate and adjust. Press and release the knob to select a function or parameter for adjustment (in manual mode). Press and release to lock in that function (in manual mode). In some modes it only navigates vertically, to the next selection as the function is automatically selected by default. <i>Press in and hold while adjusting parameter values to adjust in larger increments.</i>
6	PowerSet Key	This key is pressed to activate the Synergic PowerSet menu. The LED will light to both confirm and remind that the PowerSet mode is activated.
7	Up/Down Arrow Key	The up down arrow key is primarily used navigate vertically. In the PowerSet mode, it navigates vertically, but when vertical navigation is exhausted, it begins to navigate horizontally through the menu.

Component Identification and Explanation

Starting-up the Welder

WHAT TO EXPECT ON START UP.

Before the first start and use of the machine, check all your connections. Make sure all fittings are tight and that your gas cylinder valve is fully open. Put on proper safety equipment (PPE) and fire resistant clothing. Make sure all accessories are uncoiled and properly connected. Inspect the accessories and ensure that they are in good working order.

WARNING! *Accidental arc flashes and burns could be possible if the foot pedal or torch switch is depressed at the time of start up. Uncoiling accessories and dismantling them from the cart is important to prevent accidental triggering, arc flashing, welder damage and possible injury.*

When the welder is switched on at the rear of the unit and the start-up process begins, it will greet you with the start-up screen while it is booting up. All LED lights on the front panel will light up on the front to allow you to inspect their functionality. The boot-up will take a few seconds as the machine re-adjusts for the voltage input and recalls the last settings used. *The boot up screen should look similar to this:*



During the boot-up process you may hear a series of slight clicks, thuds, or thumps as the machine switches relays and solenoids. This is normal.

It's important to note that similar thuds or clicks that are heard on start up can also be heard as the machine swaps processes or when certain functions are selected. This is normal and should not be of concern.

When fully booted up, the screen should look similar to this, depending upon the actual process and functions selected:

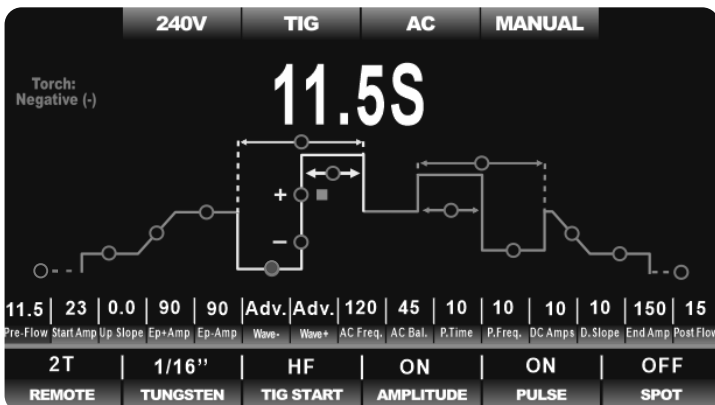

Depending on the fan settings in the background menu, the fan may or may not start when the machine is switched on. Be sure to check the fan setting is on your machine before welding and select the type of fan operation you desire. *See discussion about fan settings and how to access the fan and cooler controls found in the Quick Start-Up Guide and in other information found later in in the this manual.*

It is recommended that all functions be checked for proper operation every few months so that any malfunction can be noted and reported before it is needed. If any malfunction of the control screen or the welder is observed, contact Everlast Tech Support.

TAKE CARE OF THE LCD SCREEN.

The screen is a high resolution 5.1" TFT color LCD screen. It's important to take care of it. Keep the cover shut when welding or when not in use. *Additionally, cut-to-fit screen protectors can be used with the screen (and it is recommended to do so) to offer a second layer of protection and keep the screen in like new conditions. These are customer-supplied and available at local stores that sell electronic items such as computers or mobile phones.* These should be periodically removed and replaced. Lightly clean the screen only when needed with standard screen cleaning solution and lint free cloth designed for cleaning screens. Do not use harsh detergents or alcohol. The front protective cover is plastic and may get scratched if it is wiped dry. If heavy dust has accumulated, use dry compressed air to blow off the screen. Do not dry wipe with dirty rags, sleeves or gloves.

USE THIS AREA FOR MAKING OPERATION NOTES:

Component Identification and Explanation

Control Panel Operation and Navigation

QUICK NAVIGATION GUIDE: STARTING UP AND PARAMETER ADJUSTMENT OF MANUAL MENU

Complete the following steps to turn on and set up the Manual Menu. Use steps 1 through 3 for all menus.

1. Turn the welder on using the power switch on the rear.
2. After the welder is turned on, the boot up screen will appear. All LED lights will light up red for a few seconds.
3. Press the left or right arrow process selector key to select the welding process. The corresponding LED will light.
4. To select a parameter for adjustment, rotate knob left or right. The chosen parameter will turn red.
5. To make an adjustment to a parameter, press knob once. The parameter will enlarge and value will turn red.
6. Rotate knob to change the value of the parameter.
7. Press knob again to save and lock in parameter. The parameter will return to white and shrink slightly in size.
8. Repeat Step 4 through 7 until all desired parameter adjustments are made.

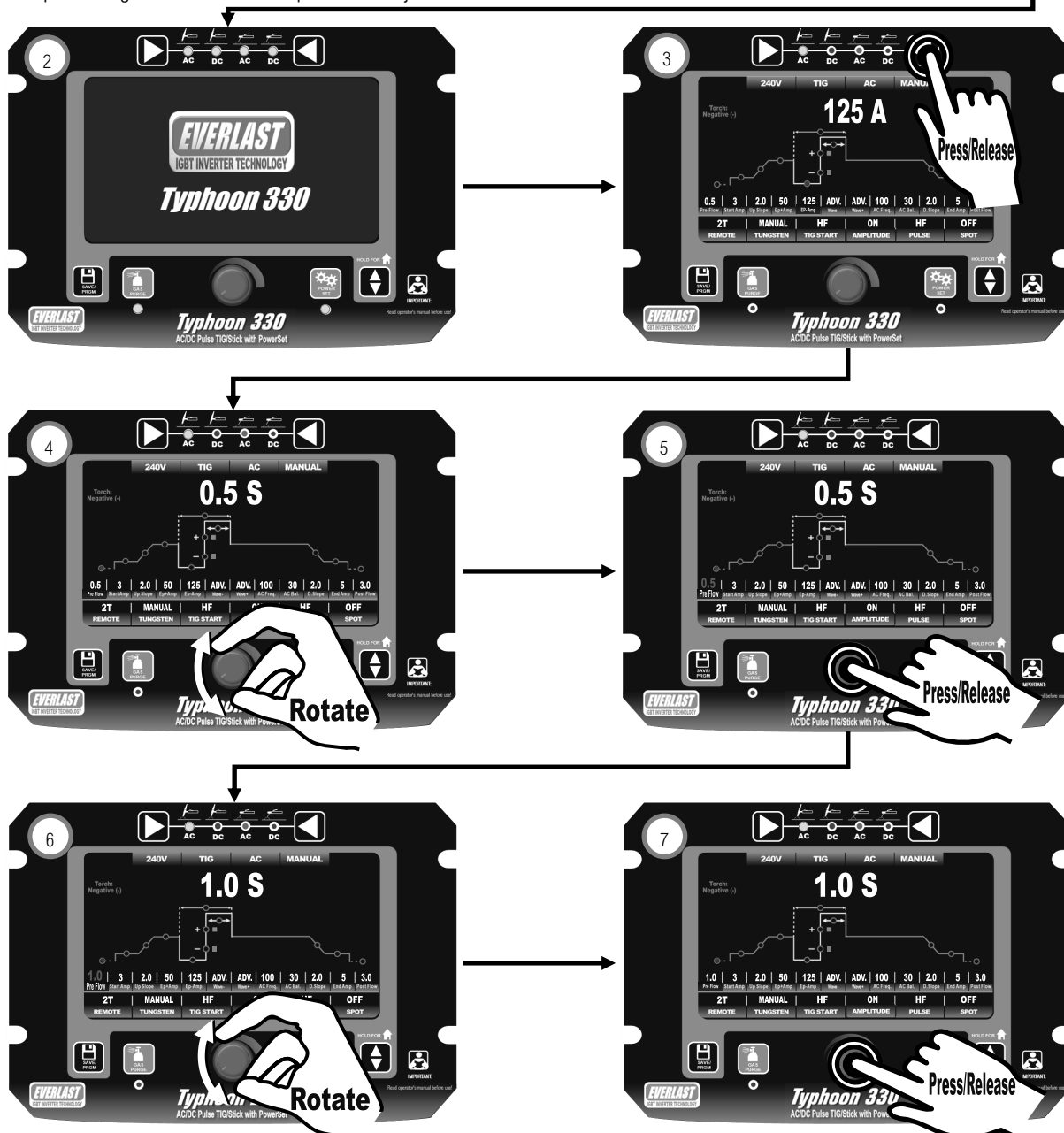
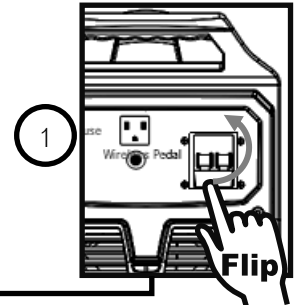

NOTE: Adjusting some parameter values may be tedious due to the wide range of adjustment. To speed up adjustment, push in on the knob and hold it in while turning. This will allow you to adjust in whole units or units of 10. Complete any fine adjustment by releasing the knob and continuing to turn.

Component Identification and Explanation

Control Panel Operation and Navigation

QUICK NAVIGATION GUIDE: FUNCTION SELECTION AND ADJUSTMENT OF MANUAL MENU

Complete steps 1 through 3 on the previous page before completing the following instructions.

1. Press the up/down navigation key once to select the Function line at the bottom of the screen. The Function line automatic defaults to the Remote Function and will be highlighted in Red. The status or mode of the function will display in the bottom as well as at the top of the screen.
2. Rotate the adjustment knob right or left until the desired function is selected and highlighted.
3. Press the adjustment knob and release to select and ready the Function for status or mode change. The selected Function is ready to be changed.
4. Rotate the adjustment knob to change the mode or status of the Function.
5. Press and release the adjustment knob again to save and lock in the status or mode change. The selection will shrink and status will turn white when it is deselected.
6. To return to the Parameter setting line, press and release the up/down navigation key or wait five seconds for it to return automatically.

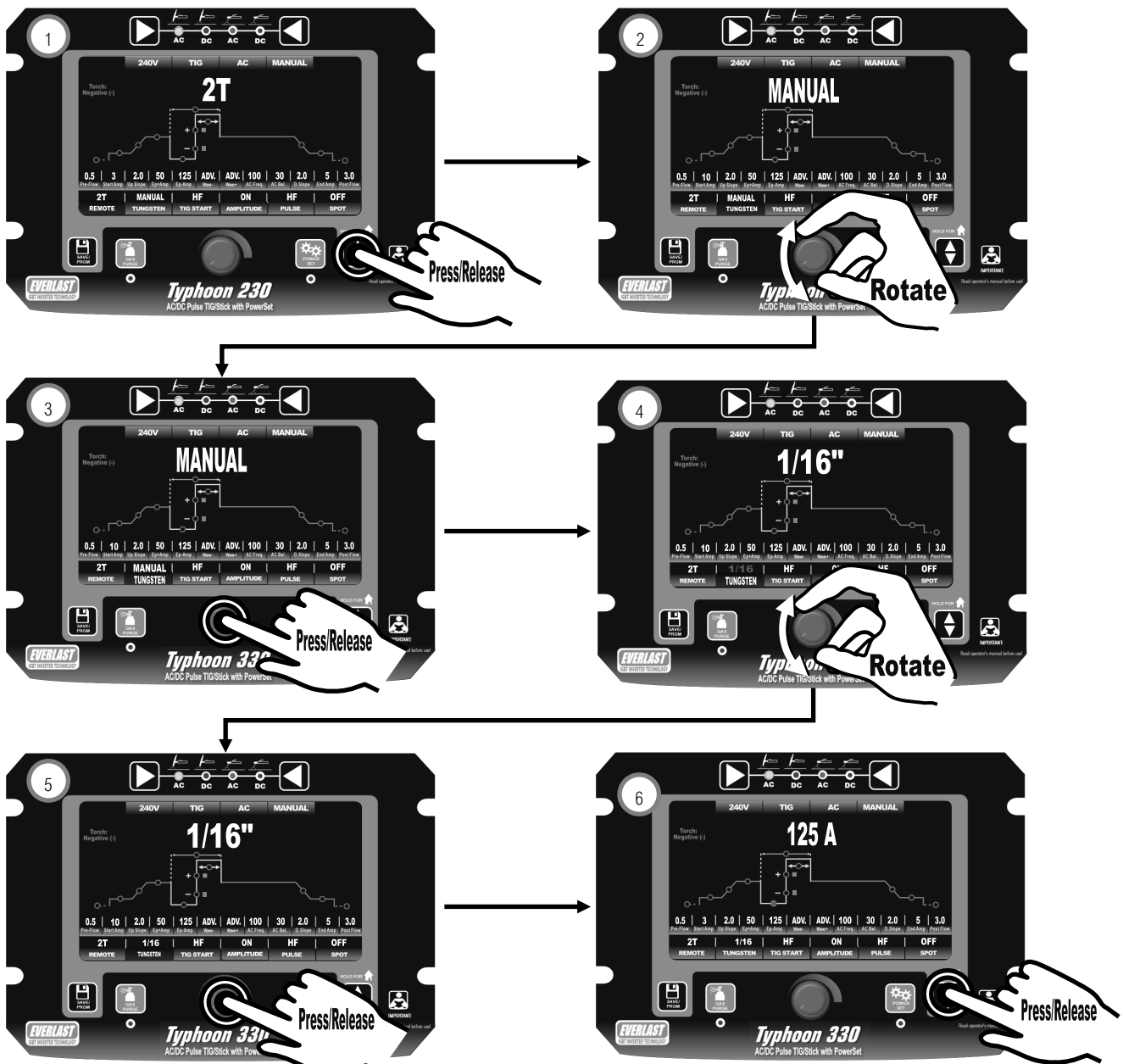

Component Identification and Explanation

Control Panel Operation and Navigation

QUICK NAVIGATION GUIDE: ADJUSTMENT AND NAVIGATION OF POWERSET MENU

The basic navigation of the PowerSet screen is similar to the manual setup screen. However there are differences that should be noted. The PowerSet Menu requires input of various pieces of information by the user. Each line will need to be navigated to sequentially, from top to bottom, with the left column first, then the right. The Function line is navigated to last. Use same start up procedure for PowerSet mode.

1. To engage the PowerSet mode press and release the PowerSet key. The red LED should light continuously and PowerSet screen is displayed. The PowerSet menu defaults automatically to the Amperage pane, which allows the user to fine tune the setting after all inputs have been made.
2. To change input or function settings, navigate to the desired Input setting or function with the up/down navigation key by pressing and releasing repeatedly until the desired input or function has been highlighted. Inputs will flash on and off. Functions will remain solid but will be highlighted in red and the status of the function will turn red when selected.
3. To make a change in the function or input, such as plate thickness or type of remote function, turn the adjustment knob. Do not press before adjusting (as you would do in manual mode). The function is automatically selected since each line or box has a single adjustment. The corresponding input value will highlight in green when the adjustment knob is turned. The Function will change status as the knob is rotated.
4. Use the up/down navigation key to return to the Suggested Amperage setting, or wait five seconds and the unit will automatically default back to the Suggest Amperage setting.

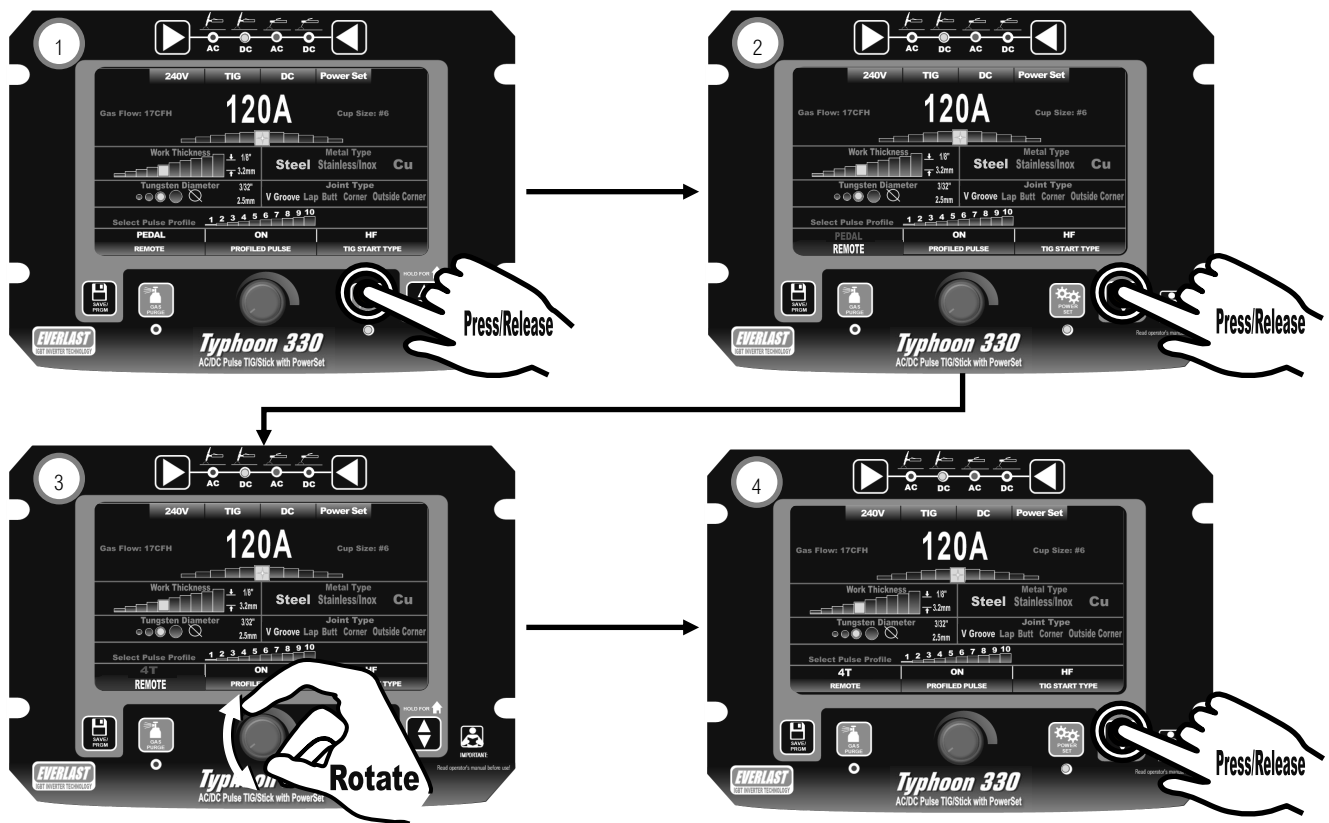

Component Identification and Explanation

Control Panel Operation and Navigation

QUICK NAVIGATION GUIDE: SELECTING AND ADJUSTMENT OF BACKGROUND MENU

The Background Menu screen contains several user preference settings along with welder status information that are not normally adjusted or in need of monitoring. The process of accessing and adjusting this menu is a bit different from other menu screens. Once these items are set to the user's preference, they are not usually changed unless changes are required for special applications.

1. Startup the machine normally.
2. Once machine is fully booted up and operating normally, using two fingers, **press and hold** the Program/Save Key and the Gas Purge key found on the lower right of the screen **simultaneously**. This will take a couple seconds for the machine to recognize the input combination. The Menu screen will appear. When the Menu screen appears, release the keys.
3. Rotate the adjustment knob until the desired feature is highlighted in Green.
4. Press and release knob to select feature desired for adjustment. The feature text will highlight in Red.
5. Rotate knob to change and select the status/value of the feature. Line items 7, 8 and 9 monitor the unit's core temperatures and are not adjustable.
6. Press, hold and release the Navigation up/down arrow key to return to the home screen, or wait 5 seconds and it will return automatically.

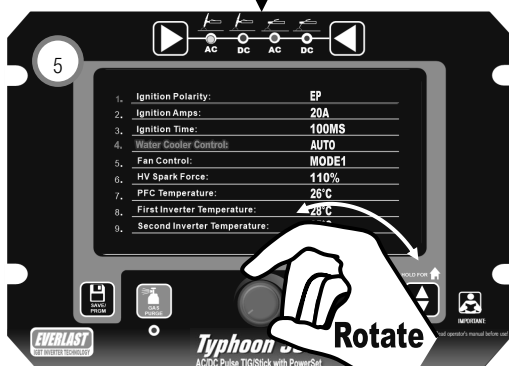
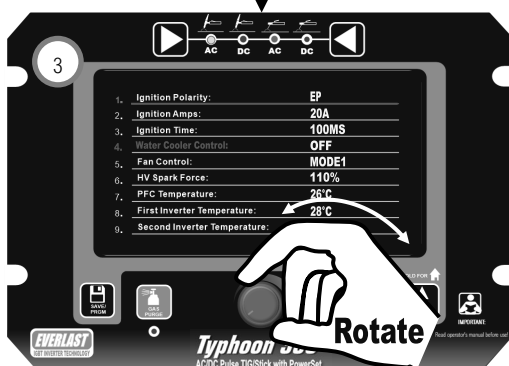
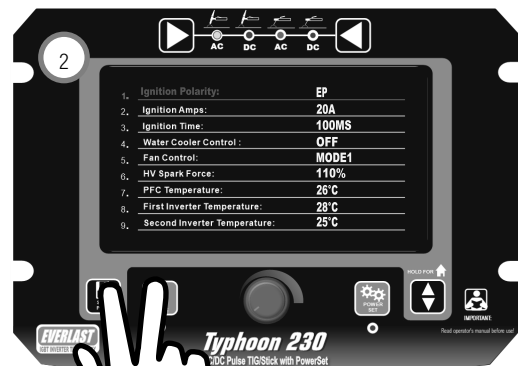

Component Identification and Explanation

Control Panel Operation and Navigation

QUICK NAVIGATION GUIDE: PROGRAM AND SAVE FUNCTION

The Program and Save function can save up to 30 different programs, of any combination of TIG, Stick or PowerSet mode settings. It also features a lock setting to ensure quality control by preventing tampering of the base saved program unless purposefully unlocked by a unique button press. This unit has been pre-programmed with proxy programs which serve only as place holders. These programs are not designed for actual use and are meant to be saved over. To save a program, select any desired program number, regardless of name/ description/category. After saving the new program using the steps below, a new program name/description based on the basic program characteristics you have programmed will appear, and rename the program. Anytime a program is saved it should be locked to prevent tampering or alteration. Any unlocked program can be resaved over.

1. Select a desired mode and set all the parameters and functions. When all parameters and functions have been set to the desired settings and you are sure there are no more changes to be made, proceed to step #2.
2. Press and release the Save/Program key. This will bring up the Program screen. The screen will default to Program #1.
3. Rotate knob to the desired **unlocked** line representing the storage location/program number. This will highlight the text in green.
4. Press and hold the Save/Program key until the screen for 5 seconds or until the screen registers a program change in name. If a program is similar to the program being saved over, no difference in appearance may occur. Regardless, the program will be saved after 5 seconds. Release.
5. If desired, the program can be locked for quality control standards. To lock, press the Gas-Purge key. This will lock the program. *Be sure to record the program number and program name in writing for future reference and recall. Be sure to include the setting parameters in record.*
6. Press and release the Save/Program key to return to the program menu, or wait 5 seconds and it will return automatically to the menu.

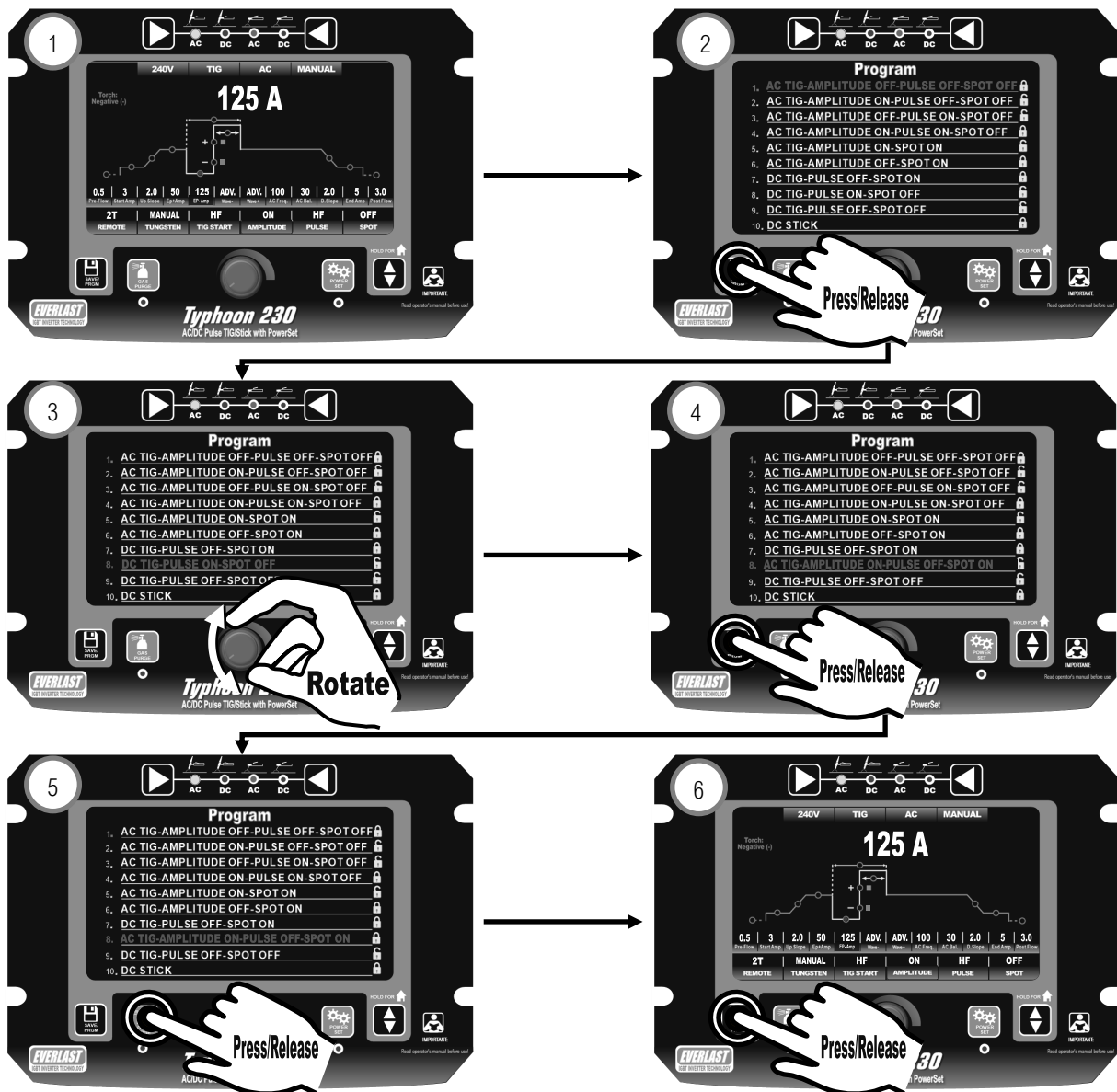

Component Identification and Explanation

Control Panel Operation and Navigation

QUICK NAVIGATION GUIDE: GAS PURGE FUNCTION AND FLOW RATE ADJUSTMENT

The Gas Purge function allows you to test and set the shielding gas flow rate. The Gas Purge key itself controls this, but it also serves as the lock function while saving a program, and it is used in simultaneous combination with the Save/Program key to access the hidden menu. Those functions are explained in the related pages in the quick navigation guide. But to use the Gas Purge function itself, use the following steps.

1. Startup the machine normally. Allow the boot screen to clear.
2. When the main operating menu appears, press and release the Gas Purge key. The LED under the key will light to indicate it that the gas purge has been activated. The solenoid should open with a slight click. If the regulator valve is open, gas should flow. If not, check the cylinder valve and the regulator control.
3. Open the cylinder valve fully and adjust the regulator to the gas flow rate suggested in this manual for the size cup you are using. See page 20.
4. Press and release the Gas Purge key. The LED will turn off and the gas solenoid valve will close.

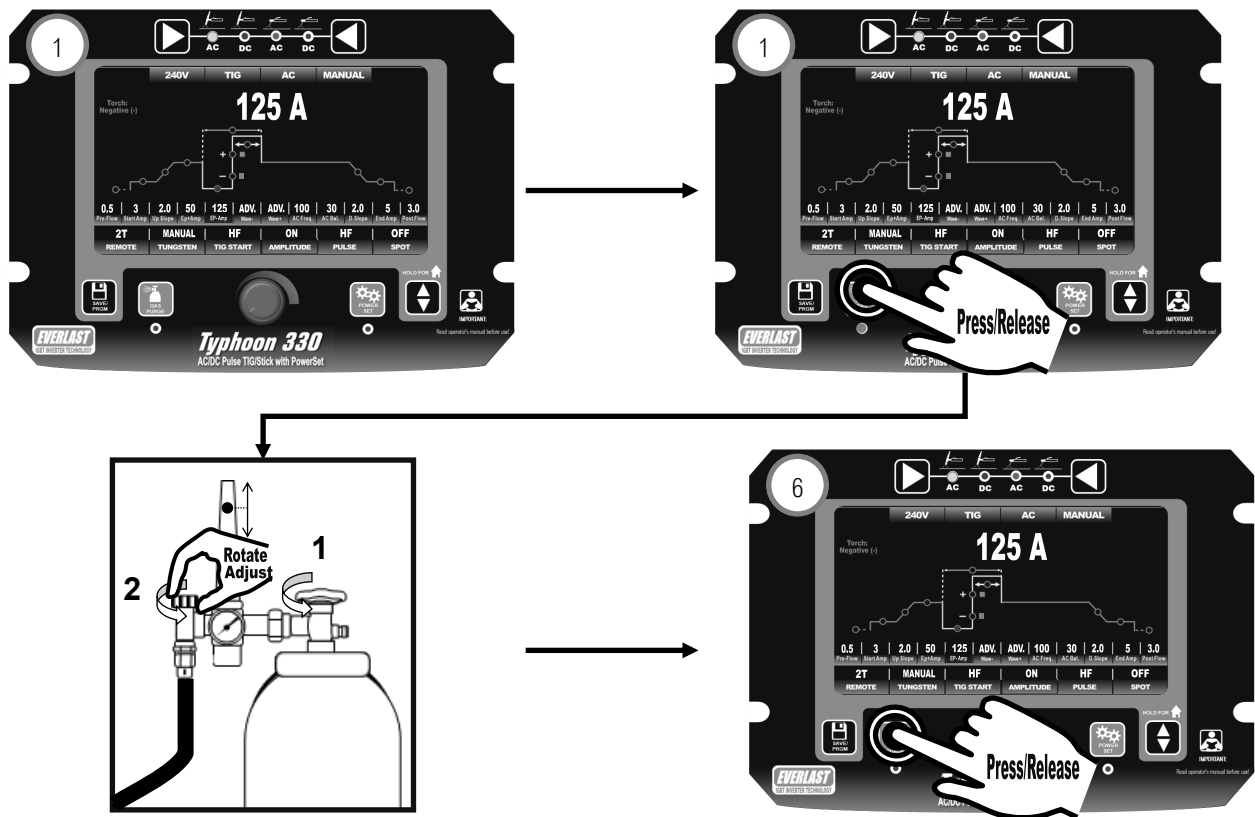

Component Identification and Explanation

Control Panel Operation and Navigation

NAVIGATING THE PANEL AND SCREEN: MANUAL MODE.*

The controls of the Typhoon are simple to use. Overall navigation is fairly intuitive with minimal clutter of keys and control knobs. When the user interface was designed, it was important to eliminate as many hidden menus as possible. The number of hidden menus has been limited to one. It requires a combination key press to access deep operating parameters that will not be regularly adjusted. This is done to limit access by untrained or unqualified personnel. It has been equipped with an “auto-home” function that allows the unit to default back to the main Amp setting after 5 seconds if no input has been made. **NOTE: The manual menu screen depicted below is a TIG menu, but Stick Mode is similar in adjustment and operation.**

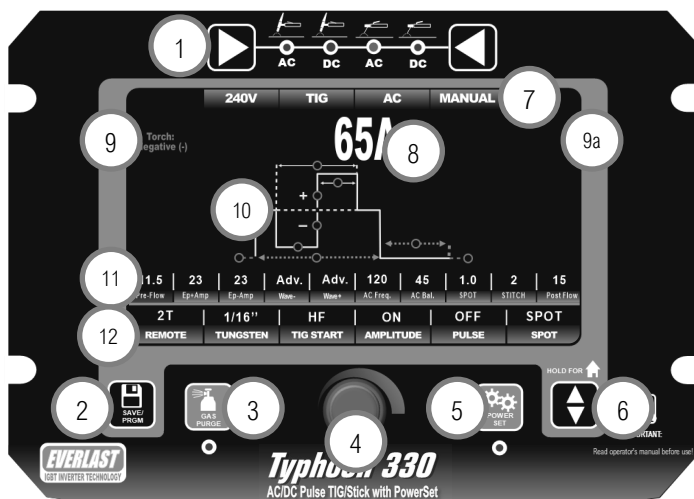

See the information below list for a basic understanding of the functions and features of the control panel and screen:

- 1. Function Selector.** The left and right keys allow the user to move left or right to select between AC TIG, DC TIG, AC Stick, and DC Stick. As the keys are pressed the LED will move to the next function. When the function has been selected, the appropriate screen will be displayed and will be ready for further adjustment and navigation.
- 2. Save/Program Key.** The Save/Program key pulls up the program screen when pressed. When pressed in simultaneously and held along with the Gas Purge key (#3), the hidden parameter menu will be brought up.
- 3. Gas Purge Key.** When pressed, the LED light will illuminate and the gas solenoid valve will open to allow the user to set the gas flow rate without having to trigger the torch. To stop constant gas flow, press again and the LED will turn off and the gas flow will cease. When pressed in simultaneously and held along with the Save/Program Key (2#), the hidden parameter menu will be brought up.
- 4. Adjustment and Navigation Knob.** This knob has several related duties that it performs in relation to navigation, selection and adjustment. It is used to navigate, select, highlight and adjust each line of parameter (#11) and function (#12). To navigate to the parameter or function on each line, the knob is turned clockwise or counter clockwise. The knob will then scroll one parameter or function for each click the knob makes. To highlight and select the function and to enter the adjustment mode, press the knob again. To adjust the selected parameter value or selected function status, twist the knob left or right to increase or decrease value or change function status. To save and exit the parameter value or function status, press the knob again, or press the up/down arrow key (#6). **NOTE:** By default, this unit allows very fine, incremental adjustment while the knob is being turned. If more rapid adjustment is needed, press and hold knob while turning to adjust the operating parameters in larger increments.
- 5. PowerSet Selector.** The welder has a synergic setup function called PowerSet for rapid setup. When you select this function, a new screen will appear. This screen will require you to input certain information about what you are welding and it will automatically give you useable settings for most applications. This function can assist new hires or pro users that need a fast, simple setup process. Many functions and parameters will be pre-set or have limited adjustment.
- 6. Up and Down Arrow Key.** This key is used to navigate vertically on the manual menu screen between the Parameter Line (#11) and the Function Line (#12). When using the PowerSet function, it is used to scroll both horizontally and vertically through the user input settings. In this mode, each separate press of the key navigates to the next set of user input data and readies the welder for more user data input and adjustment. The key navigates vertically on the left column then navigates to the right column and finally across the bottom Function Line.
- 7. Screen Information and Status Bar.** The upper information and status bar is available in both the Manual and PowerSet mode screens. This bar is designed to confirm and remind the user of the welding modes, and operating voltage of the machine. The operating voltage indicator serves both as a reminder and as a diagnostic tool, in case the machine is not sensing 240V because of faulty input wiring.
- 8. The Parameter Value Display Area.** In Manual setup mode, the area at the top of the screen with the large, white numbers and letters always reflects the value of the parameter or function that has been selected for adjustment. If a parameter is selected for adjustment, it will include type of value being displayed as well as well. For example, for the example if the parameter value is 65, the screen may display the value as Percent (%), Hertz (Hz), Amps (A), or Seconds. Wave Form parameters are the only non-numeraled parameter that will be displayed on the Parameter Line (#11). In the case of the Function Line (#12) the function itself will be displayed in an expanded less abbreviated form when it is selected and adjusted.
- 9. Polarity Reminder/Volt Readout.** The Polarity reminder is in the upper left corner to remind the user to check and use the polarity that is listed. **9a:** In stick mode the unit also displays OCV and weld voltage

Component Identification and Explanation

Control Panel Operation and Navigation

on the opposite side in the upper right corner.



Above image is duplicated from the previous page for reading convenience.

- Weld Cycle Graph Line.** The Weld Cycle Graph line serves as a key visual guide that helps the user to better understand the role that the selected parameter plays during the full weld cycle. The Weld Cycle Graph represents all the relevant aspects of the weld cycle from beginning to end. As each parameter in the Parameter Line (#11) is selected for adjustment by using the adjustment/navigation knob (#4), the small circle on the graph line that represents the location of the selected parameter during the weld cycle will be highlighted red to indicate and visually confirm the parameter being selected. As the knob is rotated clockwise to the next parameter the red light will shift right to the next logical function on the line. Conversely, turning the knob counter-clockwise causes the light to shift to the parameter to the left. As certain items on the Function Line (#12) are turned on or selected, the graph will expand or transform in appearance. In some cases such as when the Spot Weld function is selected, the graph will change more drastically and many items that are not relevant to the function will be removed from the graph. See "Understanding the Weld Cycle Graph" information in this section on next page.
- Parameter Line.** The Parameter Line represents all parameters available for adjustment. From left to right, each parameter represents the logical order and progression of the weld cycle from start to finish and corresponds to the order of the Weld Cycle Graph. Press and release the adjustment/navigation knob (#4) and then rotate the knob to highlight the next parameter for adjustment. Press the knob again to enter the adjustment mode so that the value can be increased or decreased by turning the knob. When the parameter has been highlighted and selected for adjustment, the selected parameter and its number value will turn red and expand slightly for better readability. Depending upon the function that has been turned on or selected on the Function Line (#12), the Parameter Line may expand, adding more parameters. In some, but not all cases, when the function is no

longer needed or is changed, the Parameter Line may contract and delete the irrelevant parameters from the Parameter Line.

- Function Line.** The Function Line represents the features and functions that are available that can be used to customize the weld cycle and general operation of the welder. Use the Up/Down Arrow (#6) to select the Function Line for adjustment. Then, rotate the knob and press and release it to adjust the status of the function. When certain functions such as the Spot Weld function are selected, some of the other functions become irrelevant to the operation of the function. The irrelevant functions will become unavailable for selection and will turn gray to indicate the unavailable status of that function. Also, depending on the exact function that has been selected, the total number of parameters on the Parameter Line (#11) that are available for adjustment may also be affected. In this case, if the parameters are not needed for the operation of the selected function, these parameters will be either grayed-out and unavailable for adjustment or will be removed completely. If the parameter is removed, the graph line will contract as these parameters are removed.

More specific information about the Weld Cycle Graph, operating parameters, and specific functions of this unit as they relate to each process and operation are depicted and explained in the following pages.

Functions vs. Parameters vs. Status

This manual makes frequent use of both the words "functions" and "parameters" and "status". In some cases it may seem they could be used interchangeably. And in a number of cases, there may be indeed some limited interchangeability in the terms. But they are some clear differences. To clear up the confusion between the terms, here is a brief explanation of both Functions, Parameters and Status.

Functions typically indicate a condition of operation, whether something is turned on or off. A function can also indicate a mode of operation, such as 2T torch switch operation as opposed to Foot Pedal operation. Functions will dictate the way the welder behaves and what parameters are offered for adjustment to the user. For example, the selection of the Tungsten size will limit the low Amp start of the unit. All functions of the welder are located on the bottom line.

A **parameter** defines the type and range of the value that can be adjusted. Pre-Flow, Post-Flow, Up-Slope, Down-Slope, Welding Amps, Pulse Time On, etc. are all examples of parameters. Most all parameters represent a numerically based adjustment. In other words, Parameters have a value associated with them. The exception to this is the Wave Form Parameter. These are represented by words and symbols. Since the wave forms can be set independently or equal for each Half-wave of the AC cycle and can dramatically affect the weld-cycle just like numerically based parameters, these are included as parameters instead of functions.

Status is typically used to indicate the condition of a function (On, Off, etc.) or the value of a parameter. It can also indicate the static operating condition or welding mode of the welder on the status bar at the top of the menu screen.

Component Identification and Explanation

Control Panel Operation and Navigation

NAVIGATING THE PANEL AND SCREEN: POWERSET MODE.*

Navigation in the PowerSet mode is similar to navigation in the Manual mode. As far as the PowerSet control panel goes, the basic principle of operation is the same for items such as program/save key, gas purge key and up/down key as it is in the Manual mode. However, there are differences in the screen menu item lines and the way they are adjusted or set. The user input data set also differs from the Manual mode. For the sake of continuity and to highlight similarities and differences between the operation of Manual and PowerSet modes, all panel controls, functions and features already discussed in manual mode are also discussed again in context of the PowerSet mode in the information below.

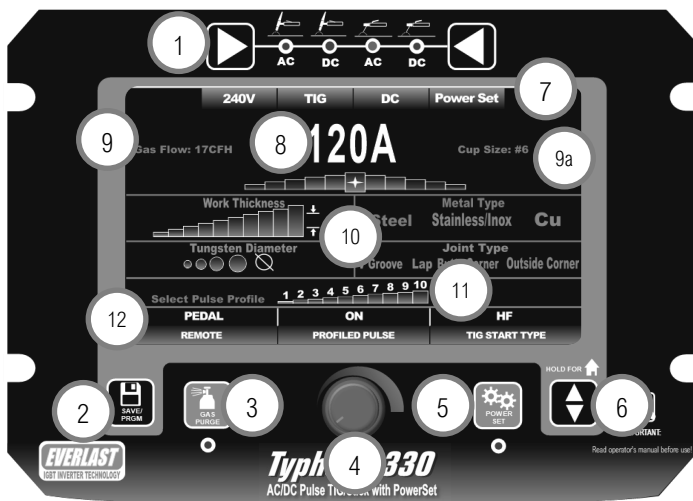

See the information below list for a basic understanding of the functions and features of the control panel and screen:

- 1. Function Selector.** The left and right keys allow the user to move left or right to select between AC TIG, DC TIG, AC Stick, and DC Stick. As the keys are pressed the LED will move to the next function. When the function has been selected, the appropriate screen will be displayed and will be ready for further adjustment and navigation.
- 2. Save/Program Key.** The Save/Program key pulls up the program screen when pressed. When pressed in simultaneously and held along with the Gas Purge key (#3), the hidden parameter menu will be brought up.
- 3. Gas Purge Key.** When pressed, the LED light will illuminate and the gas solenoid valve will open to allow the user to set the gas flow rate without having to trigger the torch. To stop constant gas flow, press again and the LED will turn off and the gas flow will cease. When pressed in simultaneously and held along with the Save/Program Key (2#), the hidden parameter menu will be brought up.
- 4. Adjustment Knob.** In PowerSet mode, the function of this knob only allows adjustment or change in an input or function. Adjust input

What is the PowerSet Mode?

The PowerSet menu screen simplifies setup by providing a starting point Amperage and by presetting many adjustable settings such as Pre-Flow, Post Flow, AC Frequency, AC balance, and pulse parameters. The purpose of the PowerSet menu screen is to reduce operator effort and setup time for new hires, and professional users that need to bypass the more extensive manual setup routine. The PowerSet Mode can be useful to beginners, but it is intended for professional users because it still requires a solid knowledge base and skills to make it work properly.

The PowerSet is able to make Amperage recommendations by requesting the user to enter known or determinable data relating to the weld such as thickness of the part to be welded (work thickness), the diameter of the tungsten being used, the metal type and the joint type. Once those inputs are complete, the unit provides the user with a useable starting point Amperage. It also suggests other standard information such as cup size and gas flow rate.

This is only a suggested starting point. The Amperage may then be adjusted up or down from that point, within limits. The adjustment limits are designed to allow fine tuning without allowing the user to stray too far off of good known settings. The adjustments will allow a basic range of 20 Amps total deviation from the recommended setting. This means the programming will allow the user to increase or decrease Amps a total of 10 Amps from the suggested setting.

As you get further away from a recommended setting, the stepped graphics under the Amperage will turn red to warn that the adjustment may be getting too far away from a desirable setting. However, it will not prevent the user from making further adjustment until the range limit has been reached. Each step represents 2 Amps of adjustment value.

Almost all function settings have been fixed at an optimum setting for general purpose use. The Profiled Pulse has 10 preset programs which allow the user to use the pulse without trial and error.

The PowerSet mode has limitations. It cannot predict all possible work conditions. If PowerSet mode does not yield satisfactory results, then use the Manual mode for full adjustment ranges and functions. It is not intended for all types of metals. Titanium is not included in this menu.

PowerSet Preset Values (For DC, omit AC References):

Pre Flow: .5 Seconds

Post Flow: 3 Seconds

Start Amps: 20A

End Amps: 20A

AC Frequency: 120Hz

AC Balance: 27% of EP+

AC Wave Form: Balanced EP+ and EN-, Adv. Square Wave

AC Independent Amplitude: Balanced Amp Setting.

Profiled Pulse Amp Setting: 35%

Profiled Pulse Time On: 50%

Profiled Pulse Frequency (Hz): #1=.5Hz, #2=1Hz, #3=10Hz, #4=50Hz, #5=100Hz, #6=150Hz, #7=200Hz, #8=300Hz, #9=400Hz, #10=500Hz

Component Identification and Explanation

Control Panel Operation and Navigation

value or change function status by turning knob. **NOTE:** Because of the nature of the PowerSet mode, both the push-to-select and the fast adjustment function have been deactivated.

5. **PowerSet Selector.** The PowerSet function serves as a synergic set-up function designed to assist the user eliminate guess work in the setup process. When you select this function, a new screen will appear and the PowerSet LED will illuminate. This screen requires the user to input certain information about what is being welded and it will automatically provide the user with useable settings for most applications. This function can help new or experienced users that need a more rapid or simple setup process. Many functions and parameters will be pre-set or have limited adjustment. There is no way to make further adjustments to the pre-set parameters.
6. **Up and Down Arrow Key.** This key is used to navigate vertically on the manual menu screen between the Parameter Line (#11) and the Function Line (#12). When using the PowerSet function, the key is used to scroll through the user input settings both vertically and horizontally. In this mode, each press of the key navigates to the next set of user input data and readies the input for adjustment. The key navigates vertically on the left column before it navigates to the right column and finally the bottom Function Line.
7. **Screen Information and Status Bar.** The upper information and status bar is available in both the Manual and PowerSet mode screens. This bar is designed to confirm and remind the user of the welding modes, and operating voltage of the machine. The operating voltage indicator serves both as a reminder and as a diagnostic tool, in case the machine is not sensing 240V because of faulty input wiring.
8. **Amperage Display.** This is the Amperage that is suggested by the machine once all the operator has input all the required operating information regarding metal thickness, tungsten diameter, metal type and joint design. A certain amount of limited fine tuning is allowed.
9. **Polarity Reminder/Volt Readout.** The Polarity reminder is in the upper left corner to remind the user to check and use the polarity that is listed. **9a:** In stick mode the unit also displays OCV and weld voltage. In TIG it suggests the cup size.
10. **User Input Area.** The PowerSet function requires several pieces of information from the operator so that the programming can accurately set the suggested Amperage. This area has several parameters that must be defined.
 - **Work Thickness.** *The thickness of the plate or sheet metal to be welded (the work) must be entered. If an exact thickness isn't listed, choose the next closest setting. Certain work thickness may limit Tungsten size selections.*
 - **Metal Type.** *Select the type of metal being welded so that the proper calibration can be made. For all mild and carbon steels, select steel.*
 - **Tungsten Diameter.** *Select the Tungsten diameter for use with the machine. Tungsten size will affect the range of adjustment and will limit some choices for work thickness.*
 - **Joint Type.** *This helps to fine tune the Amperage that is recommended slightly. Depending upon other settings, the actual suggested Amperage may not change with a change of joint type.*
11. **Profiled TIG Pulse.** The Profiled TIG pulse function makes easy work of setting the pulse. It features 10 different increasing frequency settings at useful intervals. The standard type of pulse is preset using a fixed Pulse Time On of 50% and a Pulse Amps setting of 35%. Standard pulse wave form shape is used for AC and DC. This area disappears if the Pulse Function is set to "OFF." It is not present in stick mode.
12. **Function Line.** The Function Line for the PowerSet Menu eliminates many features and reduces operator setup time. Besides the Pulse Function, the programming restricts the user to two types of functions.
 - Remote Function. The operator must choose the type of control to use.
 - TIG Start. The operator must choose the type of TIG arc start.

USE THIS AREA FOR MAKING OPERATION NOTES:

Component Identification and Explanation

Weld Cycle and Graph Line Details

The pictures used in this manual are for illustrative purposes only and may not represent every single combination or possibility of adjustment that exists. They are designed to establish basic principles of operation and setup for the user to follow. Any values portrayed in the artwork are not to be considered recommended settings or even default settings of the unit.

UNDERSTANDING THE GRAPH LINE OF THE TIG WELD CYCLE.

The graphed line of the Weld Cycle on the screen is designed to give the user a simplified visual representation of the weld cycle from the beginning of gas pre-flow phase, through to the welding phase on through to the end arc termination and post flow phases. It's designed to aid the user in understanding each weld function and the impact it has on the weld cycle. To help delineate certain additional parameters, the graph line is color coded. Common parameters found in all modes trace the green portion of the graph line. All AC welding parameters are highlighted in the yellow portion of the graph line. Pulse parameters are highlighted in the blue portion of the graph line. When not used, both AC and Pulse parameters are eliminated from the graph line, leaving only the pure DC graph line.

Each adjustable parameter is represented by an open circle somewhere along the graph line. The exact location of the circle on the graph line represents its place and role in the weld cycle. However, some parameters such as the Independent AC half-wave form control, have an indirect role on the weld cycle. These are placed on the graph in a location that most is most closely associated with the role of the parameter. When the selector knob is turned, the circle representing the corresponding Parameter Line parameter will turn red. When a parameter is selected for adjustment, by pushing the adjustment knob, the red circle will enlarge to confirm selection.

When different functions are selected or turned on, the graph will expand and contract, based on what functions and parameter settings are selected. In some cases when a function is selected, such as "Live Lift" or the status of a function is changed, the circle on the graph line parameter representing a major parameter of the graph line will not disappear, but corresponding parameter selection on the parameter line will be grayed-out and disabled for adjustment. This simply means that the parameters is either preset by the machine, or the nature of the function selected makes the adjustment of specific parameter unnecessary or moot. A clear example of this would be if the pedal mode is selected using the "Remote" function. The functions of "Up-Slope Timer" and "Down-Slope Timer" are still valid aspects of the weld cycle, but instead of being set and controlled automatically on the screen of the welder, the operator is control of it manually through the up and down operation of the pedal.

When selecting the Standard or AC Advanced Pulse function for use, a new blue graph line will be inserted into the Weld Cycle Graph Line to represent the added parameters that are needed to be able to adjust the to pulse parameters. It should be noted that AC and DC Pulse portions of the graph line are slightly different from each other.

AC TIG Graph Line:

The graph line of the AC TIG weld cycle in this example is shown in the most expanded form with all features displayed except Spot Timer. (The Spot Timer Weld Graph Line changes the graph line drastically. The Spot weld graph line is covered separately.) The actual graph line will change depending upon what functions and settings are selected. However, the operation and order of the basic weld cycle remains unchanged.

See the AC TIG graph line information and notations below:

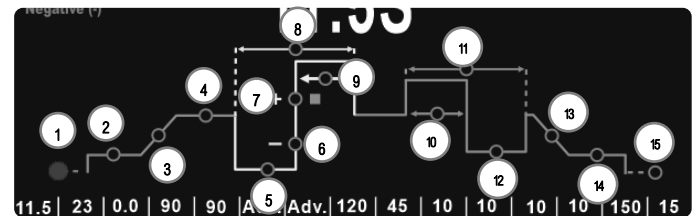

(In logical weld cycle order, from left to right priority, then up and down.)

1. **Pre-Flow Timer.** Value is in Seconds.
2. **Start Amps.** Value is in Amps.
3. **Up-Slope Timer.** Value is in Seconds.
4. **Welding Amps/ Electrode Positive.** This is the home location the welder defaults after 5 seconds of inactivity or while welding, unless "Independent Amplitude" is selected. When "Independent Amplitude" is selected and turned on, this becomes the Electrode Positive (EP+) percentage setting and the home location defaults to Electrode Negative (EN-) setting. This parameter location also serves as the high Amperage portion (also known as the Peak Amperage) of the Pulse cycle when the "Pulse" Function is turned "On."
5. **Electrode Negative.** This parameter only appears when "Independent Amplitude" is selected and turned on, this becomes the Electrode Negative location. Once "Independent Amplitude" is selected, this becomes the home location of the welder settings since it allows direct adjustment of Amps. When Independent Amplitude is deselected, this circle disappears.
6. **Electrode Negative Wave Form.** This has no value assigned to it, only shapes representing Adv. Square (square), Soft Square (rounded square), Sine (rounded, upside down U), Trapezoid (blunt triangle) and Triangular (Triangle).
7. **Electrode Positive Wave Form.** This has no value assigned to it, only shapes representing Adv. Square (square), Soft Square (rounded square), Sine (rounded, upside down U), Trapezoid (blunt triangle) and Triangular (Triangle).
8. **AC Frequency.** Value is in Hertz (Hz).
9. **AC Balance.** Value is in Percent of Electrode Positive (% of EP+).
10. **Pulse Time On.** This appears only when Pulse is selected. Value is in percent of Welding Amps (or EN-) versus Pulse Amps.

Component Identification and Explanation

Weld Cycle and Graph Line Details

- Pulse Frequency.** *This appears only when Pulse is selected.* Value is in Hertz (Hz).
- Pulse Amperage.** *This appears only when Pulse is selected.* When "Advanced AC Pulse" is selected, this becomes the DC Electrode Negative parameter of the pulse. Value is in percent of welding Amps or Electrode Negative (if Independent Amplitude is selected).
- Down-Slope Timer.** Value is in Seconds.
- End Amps.** Value is in Amps.
- Post Flow Timer.** Value is in Seconds.

AC TIG Spot Weld Graph Line:

The AC Spot Weld graph line removes many parameters from the graph line since they are irrelevant to making a rapid small weld. Slopes and Start/End Amperages are not used since the arc is either On or Off. The Spot Weld timer parameter is added to the graph line and the Stitch timer parameter, which allows the Spot Weld function to cycle on and off in a repeating fashion, is added to the graph line as well.

See the AC Spot Weld graph line information and notations below:

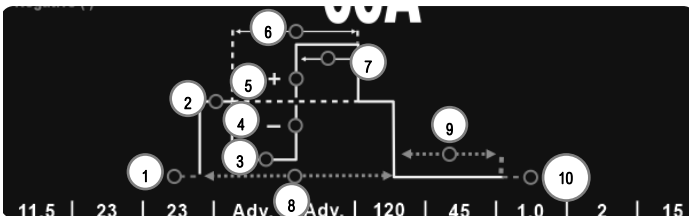

(In logical weld cycle order, from left to right priority, then up and down.)

- Pre-Flow Timer.** Value is in Seconds.
- Welding Amps/ Electrode Positive.** This is the home location the welder defaults after 5 seconds of inactivity or while welding, unless "Independent Amplitude" is selected. When "Independent Amplitude" is selected and turned on, this becomes the Electrode Positive (EP+) percentage setting and the home location is defaults to the Electrode Negative (EN-)setting.
- Electrode Negative.** This parameter only appears when "Independent Amplitude" is selected and turned on, this becomes the Electrode Negative location. Once "Independent Amplitude" is selected, this becomes the home location of the welder settings since it allows direct adjustment of Amps. When Independent Amplitude is deselected, this circle disappears.
- Electrode Negative Wave Form.** This has no assigned value. It only has wave form shapes representing Adv. Square (square), Soft Square (rounded square), Sine (rounded, upside down U), Trapezoid (blunt triangle).
- Electrode Positive Wave Form.** This has no assigned value. It only

has wave form shapes representing Adv. Square (square), Soft Square (rounded square), Sine (rounded, upside down U), Trapezoid (blunt triangle).

- AC Frequency.** Value is in Hertz (Hz).
- AC Balance.** Value is in Percent of Electrode Positive. (% of EP+)
- Spot Timer.** *This parameter is added to serve as the "Arc-On" Timer.* Value is in seconds.
- Stitch Timer.** *This parameter is added to serve as the "Arc-Off" Timer.* Value is in seconds.
- Post Flow Timer.** Value is in Seconds.

DC TIG Graph Line:

The DC TIG example of the graph line is slightly different than the AC. In pulse mode the welder has wave form adjustment. The AC does not since it is an actual wave shape. The DC graph line is more simple when compared to the AC TIG graph line. It does not have the AC features, but in nearly every other way, the graph line is very similar in appearance. The graph line of the DC Weld cycle appears here in the most expanded form from left to right, in order of operation, starting with Pre-flow and ending with Post Flow, with Pulse Activated. The Spot Weld function is not included in this view of the DC TIG graph line. It drastically changes the DC TIG graph line. The DC TIG Spot Weld graph line is covered separately.

See the DC TIG graph line information and notations below:

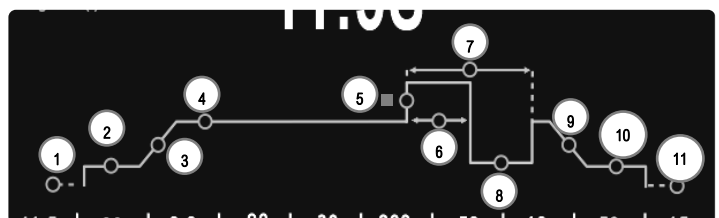

(In logical weld cycle order, from left to right priority, then up and down.)

- Pre-Flow Timer.** Value is in Seconds.
- Start Amps.** Value is in Amps.
- Up-Slope Timer.** Value is in Seconds.
- Welding Amps.** *This is the home location the welder defaults after 5 seconds of inactivity or while welding, This parameter location also serves as the high Amperage portion (also known as the Peak Amperage) of the Pulse cycle when the "Pulse" Function is turned "On."*
- Wave Form Selection.** *The DC pulse wave shape is adjustable. It has 4 wave shape patterns to choose from: Advanced Square, Trapezoid, Triangle and Sine.*
- Pulse Time On.** *This appears only when Pulse is selected.* Value is in percent of Welding Amps (or EN-) versus Pulse Amps.

Component Identification and Explanation

Weld Cycle and Graph Line Details

7. **Pulse Frequency.** *This appears only when Pulse is selected.* Value is in Hertz (Hz).
8. **Pulse Amperage.** *This appears only when Pulse is selected.* Value is in percent of Welding Amperage.
9. **Down-Slope Timer.** Value is in Seconds.
10. **End Amps.** Value is in Amps.
11. **Post Flow Timer.** Value is in Seconds.

DC TIG Spot Weld/ Fast-Tack Graph Line:

The DC TIG Spot Weld function includes a Fast-Tack function which is a process also known as “cold welding.” In design and scope, both Spot and Fast-Tack are similar. Fast-Tack differs by providing very short weld times. This combined with high Amperage settings and successive short stitch times, helps to weld very thin gauges of metal without warping, while maintaining proper fusion. The DC Spot Weld/ Fast Tack graph line removes many parameters from the graph line since they are irrelevant to making a rapid small weld. Slopes and Start/End Amperages are not used since the arc is either On or Off. Fast-Tack is not for use with Aluminum.

See the DC Spot/ Fast-Tack Weld graph line information and notations below. The Fast-Tack graph line uses the same function locations and graph line. The differences in Spot and Fast Tack items are noted below:

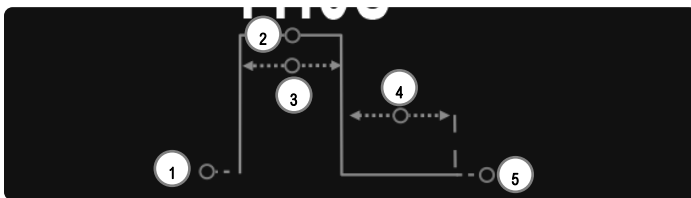

(In logical weld cycle order, from left to right priority, then up and down.)

1. **Pre-Flow Timer.** Value is in Seconds.
2. **Welding Amps.** This is the Amp setting for the Spot/Fast Tack Function. This is the default location that the welder defaults to after 5 Seconds.
3. **Spot Timer/ Tack Timer.** *This parameter is added to serve as the “Arc-On” Timer.* Value is in seconds for Spot Timer. Value is in Milliseconds when used as the Tack Timer in the Fast Tack mode.
4. **Stitch Time.** *This parameter is added to serve as the “Arc-Off” Timer.* Value is in seconds for Spot Timer. Value is in Milliseconds when used as the Stitch Timer in Fast Tack mode.
5. **Post Flow Timer.** Value is in Seconds.

UNDERSTANDING THE GRAPH LINE OF THE STICK FUNCTION.

The Stick graph line shape and functions are much different than TIG except in the fact that both share an “Amp” setting. However, the Stick function of this welder does give you complete control over practically all pos-

sible Stick welding functions that would help the user in customizing the welding arc. The adjustability that this welder offers in AC mode is far more advanced than most any other AC capable Stick welder. In DC mode, even though it is far more simple, it still offers a full compliment of practical features that help the user to maintain maximum control. As a result, when Stick welding is selected (either AC or DC) the weld cycle graph looks different and may even appear upside-down or reversed from the TIG graph line. Both AC and DC have similar functions except for the specific AC functions of the AC mode which are graphed with a yellow line. DC is represented by a continuous solid green line. Also, the Function line changes to offer more available functions in DC as well.

AC Stick Graph Line:

See the AC Stick Graph Line information and notations below:

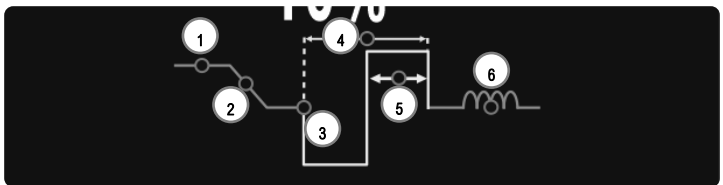

(In logical weld cycle order, from left to right priority, then up and down.)

1. **Hot Start Intensity.** Value is the percent of increase of Amperage over the Set/Main Amperage.
2. **Hot Start Duration/Time.** Value is in Seconds.
3. **Amperage.** Value is in Amps
4. **AC Frequency.** Value is in Hertz (Hz) (Not present in DC.)
5. **AC Balance.** Value is in Percent of EP. (Not present in DC.)
6. **Inductance.** Value is in Percent of reactivity/increase over the of the Set/Main Amperage.

DC Stick Graph Line:

See the DC Stick Graph Line information and notations below:

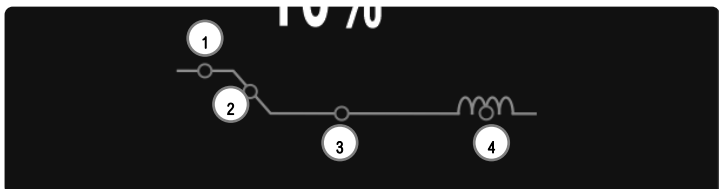

(In logical weld cycle order, from left to right priority, then up and down.)

1. **Hot Start Intensity.** Value is percent of increase of Amperage over the Set/Main Amperage
2. **Hot Start Duration/Time.** Value is in Seconds.
3. **Amperage.** Value is in Amps
4. **Inductance.** Value is in Percent of reactivity/increase over the set

Component Identification and Explanation

AC TIG Screen Setup, Functions and Parameters

For the following pages, keep in mind that while there is only one hidden menu screen designed for adjusting functions that are not commonly changed or used, the screen menu and graph line do alter the shape, size and number of parameters and functions available for adjustment, based off of the functions and process the user selects. Remember that the parameter values depicted on the sample screens do not indicate actual recommended settings or default values unless specifically noted. The values and settings are used as illustrative purposes only.

Detailed discussion of all the parameters and functions can be found in the “Explanation of Functions, Parameters and Welding Terms” in alphabetical order in the manual.

Notice in the example below that the Pre-Flow is selected for adjustment. The font is slightly larger, the numeric value above “Pre-flow” is changed to red, and the red colored circle on the graph line indicating Pre-Flow is enlarged which indicates it is in the adjustment mode. As each parameter is selected for adjustment the same thing will happen. Normally, the red highlighted circle defaults to the relevant Amperage setting until adjustments are made or after no adjustments or inputs are made for 5 seconds.

AC TIG BASIC MENU:

- NO INDEPENDENT AMPLITUDE
- NO PULSE
- NO SPOT

The AC TIG Screen menu depicted below represents the most basic AC TIG menu available in Manual mode. It serves as the foundational screen in AC TIG when functions are changed or turned on and off. As other functions, such as Independent Amplitude or Spot Welder are selected, the screen graphics will expand or contract as parameters are added or subtracted, according to their relevance to the function selected. Turning on the Spot Weld function will also remove or limit availability of other functions and parameters due to the fact that these features are irrelevant to the function of the Spot Weld function.

With the Pulse and Spot Weld functions set to “OFF” the following functions and parameters will be available for selection and adjustment except as noted.

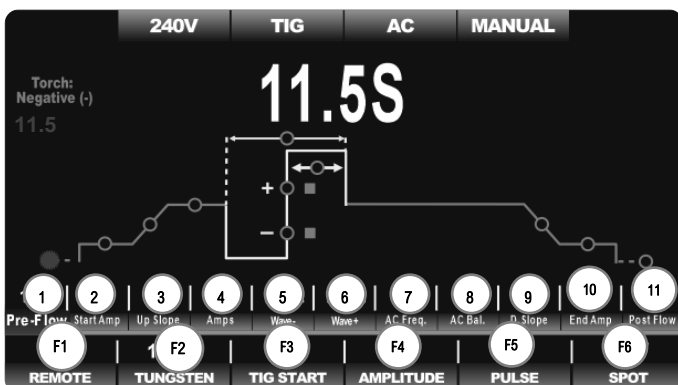

Basic AC TIG Parameters:

(In order of logical flow of the weld cycle from left to right.)

1. **Pre-Flow Time Setting: 0-30S.** Available in all Remote Function Settings. However, when TIG Start function is set to “Live Lift” it is not available for adjustment.
2. **Start Amps Value Setting: 3-330A.** Available for adjustment in all Remote Function settings. However when the Spot Function is selected, it becomes unavailable for adjustment. The Start Amp minimum will be affected by Tungsten size selection. For a lower Amperage setting select the “Manual” status of the Tungsten Function.
3. **Up-Slope Time Setting: 0-30S.** Available in the Remote Function Settings *except* Foot Pedal Mode. When the Spot Function is selected, it becomes unavailable for adjustment.
4. **Welding Amps Setting: 3-330A.** Main default AC Amp setting for the simple AC configuration. Also serves as Pulse Peak Amp Setting. *See section depicting AC with Amplitude turned on, and AC with Pulse turned on for alternative function of the welding Amp setting.*
5. **Electrode Negative Wave Form Shape Setting.** Select from Adv. Square Wave, Soft Square Wave, Trapezoid Wave, Triangular Wave and Sine Wave for the Electrode Negative (EN-) half of the AC cycle.
6. **Split Electrode Positive Wave Form Shape Setting.** Select from Adv. Square Wave, Soft Square Wave, Trapezoid Wave, Triangular Wave and Sine Wave for the Electrode Positive (EN+) half of the AC cycle.
7. **AC Frequency (Hertz) Setting: 20-400Hz.** Adjustable in all function modes of AC TIG.
8. **AC Balance Percent of Electrode Positive Setting: 5-70% of EP+.** Adjustable in all function modes of AC TIG.
9. **Down Slope Timer Setting: 0-60S.** Available for adjustment in all Remote Function settings except Foot Pedal. Not available when Spot Weld function is selected. Not available when Live Lift setting is selected for the TIG Start Function.
10. **End Amps Value Setting: 120V: 3-330A.** Available in all Remote Function settings except 4TS and Pedal. Not available when Spot Weld function is selected. Not available when the Live Lift setting is selected for the TIG Start Function.
11. **Post Flow Time Setting: 0-60S.** Available in all Function Settings.

Basic AC TIG Functions:

(In order of function numbers, from left to right.)

1. **Remote Operation Setting: Includes 2T, 4T, 2TS, 4TS, 2T plus Finger (Special Torch Req.), 4T plus Finger (Special Torch Req.) and Pedal modes.** Remote selection becomes inactive when “Live Lift” is selected. “Live Lift” creates a live tungsten and eliminates the need for triggering to start and precludes the use of the foot pedal or remote

Component Identification and Explanation

AC TIG Screen Setup, Functions and Parameters

settings.

2. **Tungsten Size Selector:** .040", 1/16", 3/32", 1/8" and Manual. Available in all Function modes. "Manual" allows lowest Start Amp settings.
3. **TIG Start Type.** Includes HF Start, Lift Start with Remote Function, and Live Lift. When the Spot Weld Function is selected, the TIG start Type becomes unavailable for selection and HF is set as the default due to the nature of Spot Welding. *Although it is available for selection in AC mode, "Live Lift" is best used for DC purposes since it runs a greater risk of Tungsten contamination.*
4. **Independent Amplitude Status Setting: OFF or ON.** For most basic mode keep setting to "Off" to keep EN (-) and EP(+) Amp value equal when Welding Amps is adjusted. When "On" is selected, the graph line and parameter line will expand to include separate settings for EN (-) and EP (+) Amp values.
5. **Pulse Status Setting: Off, Standard AC/DC (on some early models: ON), and Advanced AC Pulse.** Unavailable when the Spot Weld function is selected.
6. **Spot Timer: Off, SPOT ON.** When turned on, this function adds both Spot and Stitch Timer parameters to the graph line. Remote Operation Setting, Tig Start Type and Pulse functions are not available for selection when Spot is turned on. By default, these functions are set to "Off". Use of the Spot function overrides the Remote function and defaults to 2T (torch switch use only). Remote will be grayed out.

AC TIG FUNCTION WITH INDEPENDENT AMPLITUDE MENU:

- NO PULSE
- WITH PULSE
- NO SPOT
- WITH SPOT

Regardless of the AC function selection, or parameter settings, when Independent Amplitude is selected, the yellow portion of the graph line and the parameter line changes and expands to add Independent Electrode Positive (EP+) and Independent Electrode Negative (EN-) Amperage parameters. During standard operation with the pulse turned off, the Welding

NOTICE:

On early models of the Typhoon series, the location of the Electrode Negative (EN-) and Electrode Positive (EP+) settings were reversed from what is shown here. To improve operation flow and to make the graph more technically correct, the graph line order has been reversed to show EN- at the bottom of the AC cycle and EP+ at the Welding Amp location. Regardless, the operation and adjustment instructions will remain the same for both EN- and EP+. There is no practical difference in the adjustment procedure or parameter values.

Amps sets both EN- and EP+ Amperage. With Independent Amplitude turned off, both polarity halves of the AC cycle are locked together so that both are set equal. This is the traditional way Amps are adjusted with most TIG welders. When Independent Amplitude is turned on, the default location of the main welding Amperage is transferred. It is moved from the previous Welding Amp location on the green graph line over to the EN- location at the bottom portion of the yellow AC cycle. (See the location of the red indicator dot below The former Welding Amps location on the green line becomes EP+. The EN- value is adjusted in Amps while the EP+ value is adjusted as a percentage of EN- Amperage (ranging from 10 to 125% of EN-). The default Amperage adjustment then shifts to EN- since the EN becomes the new "Welding Amp" setting for both standard, pulse, and spot weld AC modes.

The sample below demonstrates what the weld graph should look like in the basic AC mode after Independent Amplitude is turned activated. Even though the appearance of the AC graph line and list of parameters may change when Pulse or Spot Weld is turned on, the order, appearance and function of the AC Amplitude remains the same.

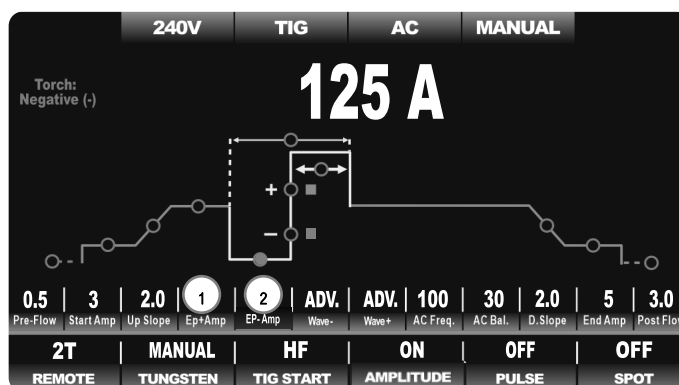

Only the additional related to Independent Amplitude parameters and functions are listed below. The other parameters and functions have been discussed in the previous section.

Additional Parameters of Independent Amplitude:

1. **Electrode Positive Amps: 10-125% of EN-.** Replaces Welding Amp Setting when Independent Amplitude is selected. When selected, it no longer serves as the default Amp location. It defaults to EN-.
2. **Electrode Negative Amps: 120V 3-330A.** This becomes the default location and value for welding Amps and represents the negative half of the AC cycle. It is also used as the "peak" current value for Pulse when pulse is selected.

Additional Functions of Independent Amplitude:

There are no additional functions when Independent Amplitude is selected.

AC TIG FUNCTION WITH PULSE MENU:

- NO INDEPENDENT AMPLITUDE
- WITH INDEPENDENT AMPLITUDE

Component Identification and Explanation

AC TIG Screen Setup, Functions and Parameters

- CANNOT BE USED WITH SPOT FUNCTION**

In AC mode, the pulse is available for selection with any function setting except with the Spot Function turned on. Once selected the graph line and the function line expand to include the Pulse settings. The pulse has two modes to select from when it is turned on. It has a standard mode which is a regular type of pulse which pulses Amperage, and the Advanced AC mode which pulses a mixed form of AC TIG and DC TIG to offer extra penetration on thicker metals and an added layer of control. The Advanced AC mode of the AC pulse function does not change the shape of the blue portion of the Pulse graph line, but it does change the operation of the pulse slightly by substituting the Pulse Amperage with Electrode Negative Amperage on the blue portion of the graph line. Do not confuse this with Independent Amplitude. These are completely separate functions, even though the function on the graph line may appear similar in shape. For further explanation see the discussion of the differences between the Standard Pulse and Advanced Pulse found in the "Explanation of Functions and Welding Terms."

Only the additional parameters and functions, from left to right, related to pulse are listed in the following information. The other parameters and functions have been discussed in the previous section.

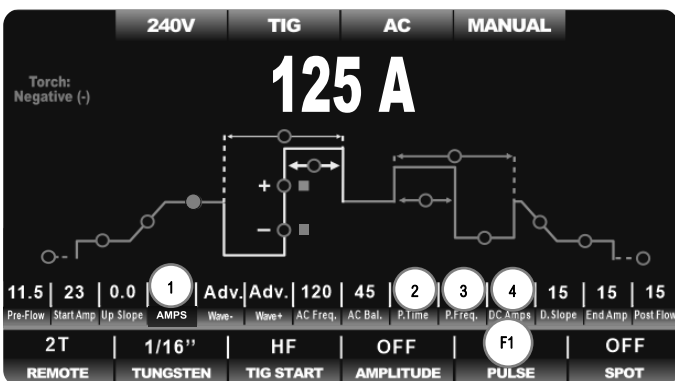

AC Pulse Parameters with Amplitude Turned Off.

- Welding Amps: 3-330A.** This becomes the default home location of the unit's programming and is used to set a singular and equal welding Amp value for both EN- and EP+. When Pulse is selected, either for Standard AC Pulse or Adv. AC pulse, this value also represents the "Peak" current value when a Pulse mode is selected.
- Pulse Time On: 5-95% of EN-Amps.** The Pulse Time-On divides the time between the Welding Amp Phase (Peak Current) and the Pulse Amperage phase (Base Current) of the Pulse.
- Pulse Frequency: 0-500Hz/0-10Hz.** This represents the number of times the pulse cycles completely in one second. Pulse Frequency can also be referred to as "Pulses Per Second." Due to the alternating nature of AC and DC of the Advanced AC Pulse Mode, the maximum Pulse Frequency is limited to 10Hz. *Early models may also limit pulse Frequency to a maximum of 10Hz if the wave form shape is split or both are not set to the Advanced Square Wave setting.*

- Pulse Amps/DC Pulse Amps: 3-100% of Welding Amps.** When Standard Pulse Mode is being used, this represents the low Amperage phase (Base Current) of the Pulse. When Advanced AC Pulse mode is selected, this still serves as the low Amperage phase of the pulse, but is referred to as DC Amps. When Advanced AC Pulse is selected and used, it is typically set at or near the to maximum value to maximize penetration.

AC Pulse Functions with Amplitude Turned Off.

- Pulse: Standard Mode and Advanced AC Mode.** When Standard Pulse is selected, the pulse operates with a pure AC wave form. The second mode available for selection is the Advanced AC Pulse (ADV.) which is a hybrid mixed pulse wave of AC and DC current. For the STD. pulse mode, early models reference "On" instead of "Standard."

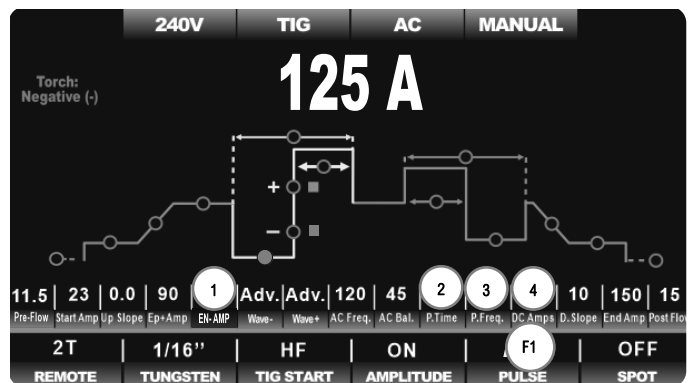

AC Pulse Parameters with Amplitude Turned On.

- EN-Amps: 3-330A.** This becomes the default (home) location of the unit's programming and represents the negative half of the AC cycle. When Pulse is selected, either for Standard AC Pulse or Adv. AC pulse, this value also represents the "peak" current value location of Pulse when one of the Pulse modes is selected.
- Pulse Time On: 5-95% of EN-Amps.** The Pulse Time-On divides the time between the EN- phase (Peak Current) of the Pulse and the Pulse Amperage phase (Base Current) of the Pulse.
- Pulse Frequency: 0-500Hz/0-10Hz.** This represents the number of times the pulse cycles completely in one second. Pulse Frequency can also be referred to as "Pulses Per Second." Due to the alternating nature of AC and DC of the Advanced AC Pulse Mode, the maximum Pulse Frequency is limited to 10Hz. *Early models may also limit pulse Frequency to a maximum of 10Hz if the wave form shape is split or both are not set to the Advanced Square Wave setting.*
- Pulse Amps/DC Pulse Amps: 3-100% of EN- Amps.** When Standard Pulse Mode is being used, this represents the low Amperage phase (Base Current) of the Pulse. When Advanced AC Pulse mode is selected, this still serves as the low Amperage phase of the pulse, but is referred to as DC Amps. When used in Adv. Pulse mode, DC Amps are typically set at or near the maximum Amperage (100%) value to maximize penetration.

Component Identification and Explanation

AC TIG Screen Setup, Functions and Parameters

AC Pulse Functions with Amplitude Turned On.

1. **Pulse, Standard Mode and Advanced AC Pulse Mode.** When Pulse is selected and highlighted, the standard operating mode with both high and low current phase of the pulse operating in AC is the first selection offered. *Early models may indicate the standard pulse mode status as "On" in the Standard Pulse mode, instead of "STD."*

AC TIG SPOT WELD FUNCTION*:

- WITH INDEPENDENT AMPLITUDE
- WITHOUT INDEPENDENT
- NO PULSE AVAILABLE
- MUST USE WITH 2T TORCH SWITCH OR TRIGGER
- HF DEFAULT START ONLY

The AC Spot Weld menu and graph line is greatly simplified and contracted in size due when the Spot Weld function is activated. A typical spot weld is a brief, but intense arc surge with a rapid termination. This type of welding eliminates the need of many parameters and functions. The Start Amperage, End Amperage, Up Slope and Down Slope parameters are eliminated from the menu screen completely. Functions which are defaulted to a required setting for Spot Welding are grayed-out and labeled with an "N/A" (Not Available) status. As a result, the menu is locked into the 2T mode and HF Start mode. The torch switch should be used with this function for proper operation.

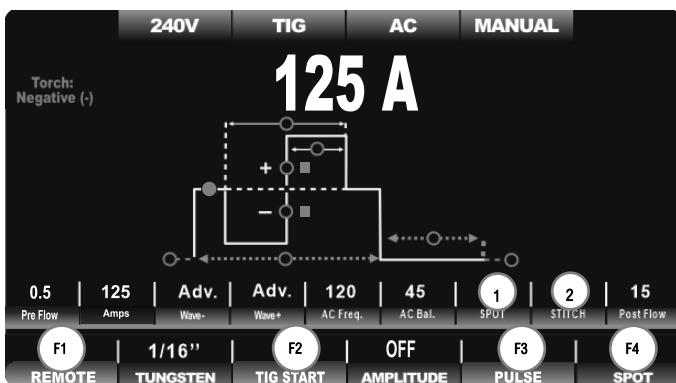

The additional parameters related to Spot Welding are listed below. Also, only functions that have a special status when the Spot Weld function is used are listed as well.

Additional AC Spot Weld Parameters:

1. **Spot Timer: .1-10S.** The Spot weld timer duration in AC mode can be programmed down to .1 seconds. This is the "Arc On" time. No shorter time can be achieved since time length shorter than this may con-

flict with achieving sufficient AC cycles to provide necessary cleaning.

2. **Stitch Timer: 0-5S.** The Stitch timer duration is the "Arc Off" time. This is designed to cycle the arc off for a specified period of time and to provide a repeating pattern of ON/OFF cycles. The idea of the stitch parameter is designed to help create an intermittent seam, with regularly-spaced welds. Used in conjunction with the Spot parameter, the length or size of the weld can be controlled. If single spot welds are desired per trigger, with no reactivation of the Arc, set "STITCH" to 0.0 Seconds.

Special AC Spot Weld Functions with Amplitude turned off.

1. **Remote: 2T.** Function is unavailable for status selection and adjustment. However, it is fixed to 2T mode. This requires the use of the mounted torch switch when Spot Welding.
2. **TIG Start: Fixed @ 10A.** Function is unavailable for status selection and adjustment. However, it is fixed to HF mode. This is because the arc must start rapidly and cleanly when Spot Welding.
3. **Pulse.** Function is unavailable for status selection and adjustment. The function is switched off due to the fact that pulse conflicts with the Spot Welding Concept. Even if it were able to be used with Spot, in theory, incorrect frequencies of the Pulse rate could interfere with proper operation of the Spot function itself due to short cycle times.
4. **Spot.** Function should be set to ON. This varies from DC and this function only has "On" or "Off" to select from. There is no Fast Tack mode for AC. This is due to the nature AC cycling at a potentially incompatible rate. Minimum Spot time is .1 seconds.

*The basic menu without Amplitude is shown. Independent Amplitude does not add or take away any basic parameters or change any function operation. As with other examples of AC discussed, when Independent Amplitude is in use the EN- location is added and becomes the default location for the Amperage adjustment. The location and operation of the Spot/Stitch timers are unaffected by this change.

Why Doesn't This Unit Have a Continuous HF Parameter on AC?

Regardless of wave form, the High Frequency (HF) on this welder is only used to start the arc. Once the arc is started, the HF shuts off when the arc transfers. This is possible, because of the fast switching times that there is virtually no "off" time of the arc as there is with a transformer welder operating on 60Hz. The transformer welder doesn't modify or change that frequency. So, in a transformer welder, the arc "outs" each time as it changes polarity. This is why HF is used to overlay the arc to provide stability and a continuous arc as the arc hits a "dead" spot. Inverters take the 60 Hz (50Hz in some regions), break it down, chop it up, and recombine the welding arc and can deliver switching speeds so fast, that even welding at AC Hertz frequencies below 50 or 60 Hz, the arc has no discernable outage so the arc remains relatively stable and smooth without the HF overlay.

Component Identification and Explanation

DC TIG Screen Setup, Functions and Parameters

For the following pages, keep in mind that while there is only one hidden menu screen designed for adjusting functions that are not commonly changed or used, the screen menu and graph line do alter the shape, size and number of parameters and functions available for adjustment, based off of the functions and process the user selects. Remember that the parameter values depicted on the sample screens do not indicate actual recommended settings or default values unless specifically noted. The values and settings are used as illustrative purposes only.

Detailed discussion of all the parameters and functions can be found in the “Explanation of Functions, Parameters and Welding Terms” in alphabetical order in the manual.

DC TIG BASIC MENU:

- **WITHOUT PULSE**
- **NO SPOT/FAST-TACK**

When the DC TIG process is selected, the menu screen closely resembles the AC menu screen, except the AC functions are removed. The graph and parameter lines and the appearance of the menu is contracted and simplified. The graph line is all green. The options available for Pulse selection are altered to allow the user to select different Pulse Wave form shapes. Pulse Wave form shapes add nuanced levels of heat management and arc performance. The Adv. AC pulse option is eliminated in lieu of Pulse wave form shapes when operating in DC TIG mode.



Basic DC TIG Parameters:

In order of logical flow of the weld cycle from left to right.

1. **Pre-Flow Time Setting: 0-30S.** Available in all Remote Function Settings. However, when TIG Start function is set to “Live Lift” it is not available for adjustment.
2. **Start Amps Value Setting: 2-330A.** Available for adjustment in all Remote Function settings. However when the Spot Function is selected, it becomes unavailable for adjustment. Start Amps will be affected by the selection of the Tungsten size. Select “Manual” setting of the Tungsten function for lowest Amperage start capability.
3. **Up-Slope Time Setting: 0-30S.** Available in Remote Function Settings

except Foot Pedal Mode. When the Spot Function is selected, it becomes unavailable for adjustment.

4. **Welding Amps Setting: 2-330A.** This is the Amperage location for DC TIG. It also serves as the Peak Current adjustment for Pulse.
5. **Down Slope Timer Setting: 0-60S.** Available for adjustment in all Remote Function settings except Foot Pedal. Not available when Spot Weld function is selected. Not available when Live Lift setting is selected for the TIG Start Function.
6. **End Amps Value Setting: 2-330A.** Available in all Remote Function settings except 4TS and Pedal. Not available when Spot Weld function is selected. Not available when the Live Lift setting is selected for the TIG Start Function.
7. **Post Flow Time Setting: 0-60S.** Available in all Function Settings.

Basic DC TIG Functions:

In order of function numbers, from left to right.

1. **Remote Operation Setting:** Includes 2T, 4T, 2TS, 4TS, 2T plus Finger (Special Torch Req.), 4T plus Finger (Special Torch Req.) and Pedal modes. Remote selection becomes inactive when “Live Lift” is selected. “Live Lift” creates a live tungsten and eliminates the need for triggering to start and precludes the use of the foot pedal or remote settings.
2. **TIG Start Type:** Includes HF Start, Lift Start with Remote Function, and Live Lift. When the Spot Weld Function is selected, the TIG start Type becomes unavailable for selection and HF is set as the default due to the nature of Spot Welding.
3. **Pulse Status Setting:** Off, Adv. Square, Sine, Trapezoid, and Triangle. The DC pulse uses selectable wave forms to affect the level of control on the pulse Unavailable when the Spot Weld function is selected.
4. **Spot/Fast-Tack Timer:** Off, SPOT, Fast-Tack. When Spot or Fast-Tack is selected, this function adds both Spot /Fast-Tack and Stitch timer parameters to the graph line. The Remote Setting, TIG Start Type and Pulse functions are not available for selection when it is set to “On”. Use of this function overrides the remote and makes it unavailable for selection and will be grayed out. It will default to 2T operation. The foot pedal cannot be used.

DC TIG PULSE MENU:

- **NO SPOT/FAST-TACK**
- **CHOOSE ADV. SQUARE, TRIANGULAR, TRAPEZOID, OR SINE WAVE FORMS**

When activated, the DC Pulse menu expands to include the Pulse related parameters. There aren't any changes in function that occur. However, the “Spot/Fast-Tack” and “Pulse” functions are incompatible and they cannot

Component Identification and Explanation

DC TIG Screen Setup, Functions and Parameters

be used together. When the Spot or Fast-Tack function is selected, even though it is available to select while Pulse is turned on, Pulse is automatically made unavailable and deactivated if Spot is on. When Spot is deactivated, if Pulse was selected, Pulse will be automatically reactivated.

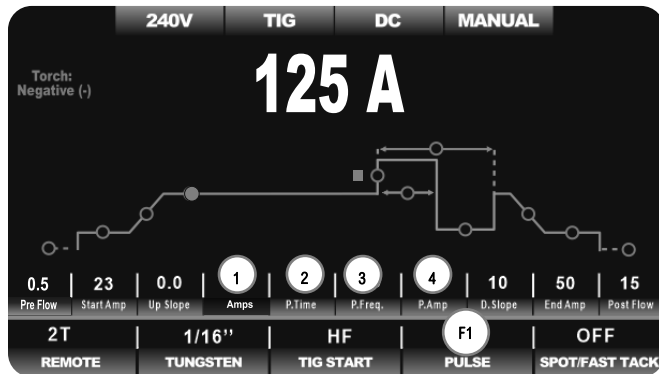

Since the rest of the parameters and functions are not changed, only the additional and relevant parameters and pulse function are listed below in logical flow of the weld cycle, from left to right. The Pulse Wave Form selection is not part of the parameter line, but is rather part of the function line. When Pulse is first turned on, this will be the first adjustment available and will be selected as part of the Pulse function. But, if there is no additional input or selection of wave form within five seconds, the programming will default back to the Welding Amps/Peak Amps location. The Wave form circle and status can only be changed from the Pulse function location and will be skipped over in normal adjustment of the other pulse parameters.

Additional DC Pulse TIG Functions.

- Welding Amps: 2-330A.** This is the default home location of the unit's programming. When Pulse is selected, either for Standard AC Pulse or Adv. AC pulse, this value also represents the "peak" current value location when a Pulse mode is selected.
- Pulse Time On: 5-95% of EN-Amps.** The Pulse Time-On divides the time between the Welding Amp Phase (Peak Current) and the Pulse Amperage phase (Base Current) of the Pulse.
- Pulse Frequency: : 0-999.9Hz.** This represents the number of times the pulse cycles completely in one second. Pulse Frequency can also be referred to as "Pulses Per Second."
- Pulse Amps/DC Pulse Amps: 3-100% of Welding Amps.** When Standard Pulse Mode is being used, this represents the low Amperage value phase (Base Current) of the Pulse.

DC Pulse Function

- Pulse: Adv. Triangle, Trapezoid and Sine.** The Pulse wave form features 4 different shapes. When pulse is active, each wave form offers a different depth of control of the pulse and imparts a distinctive, nuanced feel and weld characteristic. The Pulse wave shape indicator

is located on the weld graph line with the parameters, even though the control is located on the Function line.

DC SPOT/ FAST-TACK MENU:

- NO PULSE AVAILABLE
- MUST USE WITH 2T TORCH SWITCH OR TRIGGER
- HF DEFAULT START ONLY

The DC Spot Weld/ Fast-Tack menu and graph line is greatly simplified and contracted in size due to the nature of a spot weld. Typically a spot weld is a brief, but intense arc of Amperage with a rapid termination. A Fast-Tack weld is similar but has a much more short duration. These two types of welding eliminate the need of many parameters and functions. The Start Amperage, End Amperage, Up Slope and Down Slope parameters are eliminated from the menu screen completely. The appearance and function of both the Spot Weld setting and the Fast Tack Setting are identical, with the exception of the time unit values. Spot Weld is in .1 second increments. Fast-Tack time setting value is in milliseconds with a minimum of 10 ms. Functions which are defaulted to a required setting for Spot Welding and Fast-Tack are grayed-out and labeled with an "N/A" (Not Available) status. As a result, the menu is locked into the 2T mode and HF Start mode. The torch switch should be used with this function for proper operation. The Spot Weld setting is a longer version of the Fast-Tack Version and is used for areas where small spot welds and seams are needed. The Fast-Tack is designed for welding of extremely thin metal with extremely quick, successive on/off bursts of relatively high Amperage. The Fast-Tack is also called "Cold Welding" even though it may use relatively high Amperage in each burst.

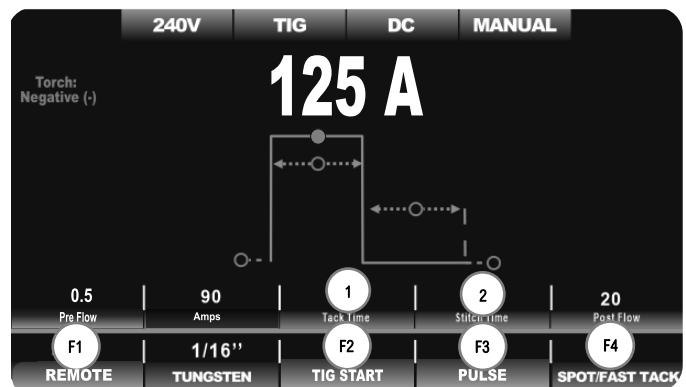

The additional and relevant parameters related to Spot Welding/ Fast-Tack Welding are listed below. Also, Spot/Fast-Tack functions that have a special status when the Spot Weld function is used are listed as well.

Additional DC Spot/ Fast-Tack Weld Parameters.

- Spot Timer, Fast-Tack Timer: For Spot .1-10S; For Fast Tack 10-250ms.** The Spot weld timer duration can be programmed down to .1 seconds. The Fast-Tack, (cold-weld) timer can be programmed down to 10 milliseconds, or .01 Seconds. This is the "Arc On" time.

Component Identification and Explanation

DC TIG Screen Setup, Functions and Parameters

2. **Stitch Timer: For Spot 0-5S; For Fast-Tack 0-25ms.** The Stitch timer duration is the "Arc Off" time. This is designed to cycle the arc off for a specified period of time and to provide a repeating pattern of ON/OFF cycles. The idea of the stitch parameter is designed to help create an intermittent seam, with regularly-spaced welds. Used in conjunction with the Spot timer, the length or size of the weld can be controlled. If single spot welds are desired for each trigger cycle, with no repeating of the Arc, set "STITCH" to 0.0 Seconds. When used in conjunction with the Fast-Tack Timer a series of rapid, successive welds are made to create a fine bead on thin gauge material without burning through or overheating the metal.

Special DC Spot Weld/ Fast Tack Functions and Settings.

1. **Remote.** Function is unavailable for status selection and adjustment. However, it is fixed to 2T mode. This requires the use of the mounted torch switch when Spot Welding.
2. **TIG Start.** This function is unavailable for selection and adjustment when either Spot or Fast-Tack are selected. However, it is fixed to HF mode. This is because the arc must start rapidly and cleanly when Spot Welding.
3. **Pulse.** This function is unavailable for status selection and adjustment when either Spot or Fast-Tack are selected. The function is switched off due to the fact that pulse conflicts with the Spot Welding Concept. Even if it were able to be used with Spot, in theory, incorrect frequencies of the Pulse rate could interfere with proper operation of the Spot function itself due to short cycle times.
4. **Spot.** The function can be set to Off, Spot, or Fast-Tack. Selecting Spot or Fast Tack results in a significant change of the graph line and parameters and functions available for adjustment. The graph line is the same in appearance between Spot and Fast-Tack.

USE THIS AREA FOR OPERATION NOTES:

Component Identification and Explanation

AC and DC Stick Screen Setup, Functions and Parameters

The Stick welding mode uses a different layout of the menu screen, with different functions and parameters than TIG. The most notable difference between AC and DC Stick welding is the polarity recommendation. AC, because of the way it references electrode positive when adjusting the AC balance, will require the Electrode Holder to be located in the negative terminal for the settings to be correct.

AC STICK MENU:

- **USE ELECTRODE NEGATIVE**
- **SOME ELECTRODES MAY NOT BE ALLOWED**
- **ADJUSTABLE AC FREQUENCY**
- **ADJUSTABLE AC BALANCE**
- **USE WITH E6011, E6013 AND E7018**

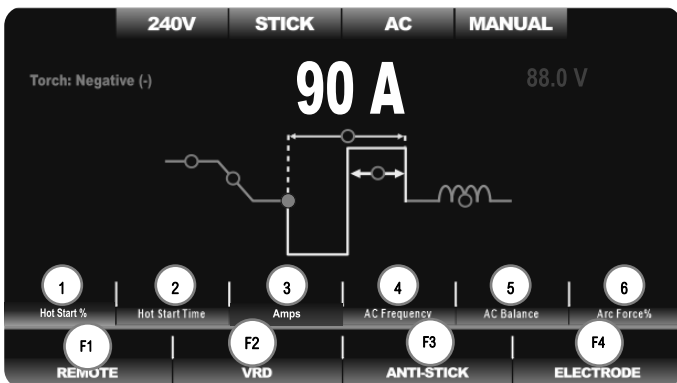

Parameters and functions are listed in order, from left to right.

AC Stick Parameters:

1. **Hot Start Amperage Percent: 0-100% over set amperage.** The Hot Start increases amperage upon arc striking to eliminate electrode sticking. This is also referred to as Hot Start Intensity.
2. **Hot Start Time: 0-2.0 Seconds.** The Hot Start Time controls the duration of the Hot Start Activity.
3. **Amps: 10-275A.** This is the main amperage adjustment. Output is capped on 120V to 100A.
4. **AC Frequency: 20-400Hz.** Increase frequency for tighter arc performance. Lower frequency for wetter AC puddle.
5. **AC Balance: 5-70%.**
6. **Arc Force.** 0-100% over set amperage. This helps to maintain constant arc and provide a steady welding wattage as voltage drops due to short arc length. This is also referred to as “dig” or “inductance.”

AC Stick Functions:

1. **Remote: Off or ON.** This unit can operate with a remote Amperage control when the Remote is set to On. For normal welding keep set-

ting to “OFF.” The foot pedal can be used in Stick mode. But in the future there may be more options for remote Amperage control. Contact Everlast for more options.

2. **Voltage Reduction Device (VRD): Less than 24V.** This function reduces the OCV to below 24V when required for safety. May make arc starting more difficult.
3. **Anti-Stick: Off or On.** This function when turned on helps to ease rod removal by reducing output when the rod sticks.
4. **Electrode Selector.** Select from rod choices: E6011, E6013 and E7018. May need to use E7018 AC rods for best results with E7018.

DC STICK MENU:

- **USE ELECTRODE POSITIVE**
- **USE WITH E6010, E6011, E6013 E7018, E308/309**

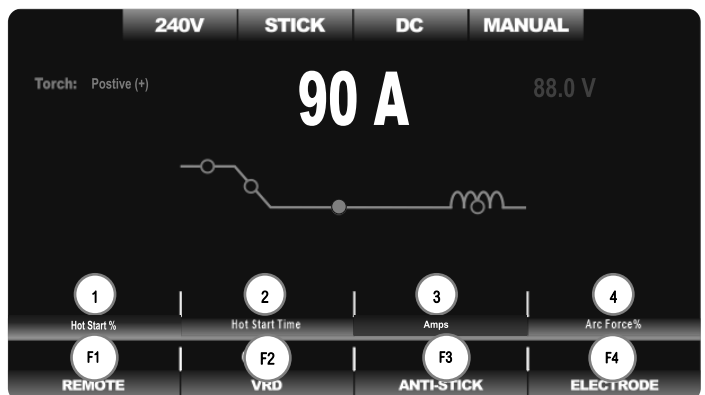

Parameters and functions are listed in order, from left to right.

DC Stick Parameters:

1. **Hot Start Amperage Percent: 0-100% over set amperage.** The Hot Start increases amperage upon arc striking to eliminate electrode sticking. This is also referred to as “Hot Start Intensity.”
2. **Hot Start Time: 0-2.0 Seconds.** The Hot Start Time controls the duration of the Hot Start Activity.
3. **Amps: 10-275A.** This is the main amperage adjustment. Output is capped on 120V to 100A.
4. **Arc Force. 0-100% over set amperage.** This helps to maintain constant arc and provide a steady welding wattage as voltage drops due to short arc length. This is also referred to as “dig” or “inductance.”

DC Stick Functions:

1. **Remote: Off or ON.** This unit can operate with a remote Amperage control when the Remote is set to On. For normal welding keep setting to “OFF.” The foot pedal can be used in Stick mode. But in the future there may be more options for remote Amperage control. Contact Everlast for more options.

Component Identification and Explanation

AC and DC Stick Screen Setup, Functions and Parameters

2. **Voltage Reduction Device (VRD): Less than 24V.** This function reduces the OCV to below 24V when required for safety. May make arc starting more difficult.
3. **Anti-Stick: Off or On.** This function when turned on helps to ease rod removal by reducing output when the rod sticks.
4. **Electrode: Select from rod choices: E6010, E6011, E6013 and E7018 or Stainless E 3XX series.** If the rod choice is not listed and you desire to weld with it, determine whether it is cellulosic (cellulose based flux) or not. If it is cellulosic, such as 7010 or 8010, then select E6010. If it isn't and is iron powder or titania-based flux or a combination, select E7018.

Component Identification and Explanation

Background Menu Screen Setup and Parameters of Operation

The unit features only one hidden background menu. It is used to access secondary control functions and operating temperatures of the unit. See the "Quick Setup Guide" in this manual to access the menu screen below.

BACKGROUND MENU:

- ACCESS ARC STARTING PARAMETERS
- ACCESS FAN CONTROL
- ACCESS COOLER CONTROL
- ACCESS AND MONITOR OPERATING TEMPERATURES

1.	Ignition Polarity:	EP
2.	Ignition Amps:	20A
3.	Ignition Time:	100MS
4.	Water Cooler Control :	OFF
5.	Fan Control:	MODE1
6.	HV Spark Force:	110%
7.	PFC Temperature:	26°C
8.	First Inverter Temperature:	28°C
9.	Second Inverter Temperature:	25°C

Menu Screen Settings and Parameters.

1. **Ignition Polarity: Electrode Positive (EP) or Electrode Negative.** Not adjustable in DC. *This does not indicate or suggest the torch polarity, but rather which half of the AC cycle the arc is started on. No single start polarity may fit all situations.*
 - Electrode Positive starting can be of benefit if you have dirty metal. It works well with AC, helping to keep the Tungsten from free from contamination during the start. However, Tungsten wear will be accelerated. It also may cause the Tungsten to ball on the start if other start parameters are set aggressively. But it is the preferred start polarity for AC, when adjusted properly.
 - Electrode Negative starts can become contaminated. The Tungsten will stay sharper longer, particularly when making multiple, rapid restarts. But starts may not be as reliable on AC. This is the standard Start for DC. Offers no cleaning on initial surge.
2. **Ignition Amps: 5-50A.** This is the micro-surge Amperage that is required for arc ignition. This is a brief surge that happens in all TIG welders to help establish the arc cleanly. Increasing the Amps however will make arc starts aggressive and may increase burn through on thin metals despite the Start Amp setting. Too low of amperage, and arc starting/transfer may not be stable or consistent. With larger diameter Tungsten, use higher Amp settings for reliable starting.
3. **Ignition Time: 0-400ms.** This is the amount of time the HF pulse stays active trying to start the arc. If the Arc doesn't initiate by the time set, the arc start attempt will be aborted.

4. **Water Cooler Control: ON/OFF.** When set to "Off" the cooler runs full time. When set to "On", the cooler starts running as soon as the arc is struck. It automatically turns off after a few seconds after the arc is terminated to keep water circulating through the torch to cool it down. The cooler itself has no control. This simply switches the power supply to the cooler on and off as needed to start and stop the cooler. If using with Fan Control Mode 1, the cycling of the cooler and the welder will not be synchronized. Set to Mode 2 to synchronize the starts of both the cooler fan and the welder fan. **NOTICE:** *The cooler fan and pump always are on at the same time.*
5. **Fan Control: Off/Mode 1/Mode 2.** When the Fan Control is set to "Off" the fans will run full time. When set to Mode 1, the fan will run when the inverter temperature reaches 140° F (60° C). When Mode 2 is selected, the fan will start upon arc strike (upon demand). Mode 2 is the safest method of fan control and provides the best compromise between the fan running and duty cycle performance.
6. **HV Spark Force: 50-110%.** This is the strength of the Arc start. Although it's called HF for the sake of familiarity, the arc start is actually generated by a High Voltage solid state board that simulates the HF start characteristics, without the aid of old style points. This helps to fine-tune the force of the HV (HF) arc during starts.
7. **PFC Temperature.** Monitors the power factor correction control circuit temperature.
8. **First Inverter Temperature.** Monitors the main inverter temperature.
9. **Second Inverter Temperature.** Monitors the AC inverter temperature.

How Does Knowing the Welder Temperature Help?

The inverter temperatures are monitored by sensors that are designed to trigger the over temperature protection of the unit and provide a signal to the fans to energize when the temperature exceeds 140°F (60°C), when Mode 1. Any of the three main sensors exceeding this temperature threshold will trigger fan operation automatically.

By periodically monitoring the temperatures:

1. It provides an indication of how well the unit is performing in work conditions.
2. It can help determine if the heat sinks are getting dirty by an over all increase in average temperature at idle.
3. It can also be used as a diagnostic to check for proper fan operation.
4. It is also good to check the temperature if you suspect a faulty temperature sensor. Any sensor not giving a similar reading to the others within a few degrees or customary reading based off of previous readings, or no reading will show up here.

Component Identification and Explanation

TIG Arc Starting, Remote Functions and Operation

The TIG arc start can be performed in three basic ways.

The first and primary arc starting method used is **High Frequency Start**. HF start is a contactless start which is performed by holding the Tungsten off the metal about 1/8" or less and using the remote to activate the HF which will send a high Voltage impulse to the Tungsten, causing the arc to jump and create continuity to the work, allowing the inverter to kick in and put out a normal welding arc. This is the most preferred way of starting, especially with Aluminum. The tip of the Tungsten is not easily contaminated this way, and it requires little skill to perform. *While this unit technically is*

considered an HV start, it electronically simulates the HF start. It is referred to HF on the Function line of the machine to eliminate confusion by the average user, but in the more technical background menu, it refers to HV start. For the purpose of the manual, HF and HV are treated as the same thing.

The second method is **Lift Start** which requires direct, purposeful contact with the surface of the metal to create continuity followed by a quick lift-off of the Tungsten to strike the arc. To understand how this works, when the Tungsten is touched to the metal, there is a small current supplied to the tip. At the time the Tungsten is lifted up, the welder senses the break of continuity. Then, the inverter sends full output to the Tungsten tip as the arc is established through the small spark created by breaking continuity. This form of Arc Starting is used when people need to start an arc without the use of an HF energy being present which can interfere with sensitive electronics nearby. It works well with steel, stainless and similar metals. It can work with Aluminum, but there is a chance of contamination of the Tungsten and more rapid wear.

The third method is the **Scratch Start** method. This method involves a full current start with a live Tungsten that requires the Tungsten to be lightly, but quickly scratched on the metal, or drug quickly over the filler wire which is temporarily touching the metal to draw and strike up the arc. The quick brush across the metal can create a skipping motion if not performed correctly which can result in a stuck Tungsten. This is the least efficient method, but is in common use in the field with basic DC TIG rigs that have no automatic control of shielding gas and use a gas-valve torch. However this unit is not equipped with this type of function, though Live Lift can function similarly while also providing automatic control over the gas. Live lift can also be used with a TIG Rig with a valve controlled torch, *but* the solenoid will need to be covered when not in use. Use the plastic dust caps that are included with the unit and are installed on the fittings of the welder to cover the holes when the solenoid gas valve will not be used.

How Do I Perform an HF Start?

1. Place the point of the tungsten 1/8" or less over the work piece.
2. Press the torch trigger or foot pedal, and the HF spark will be emitted. It may appear as small sparks or lighting if the arc doesn't start immediately. (If Live Lift is used, no pedal or trigger is required.)
3. Once continuity establishes, the welding arc will begin. You may begin to advanced the torch when a puddle forms. Maintain 1/8" height or less while welding.

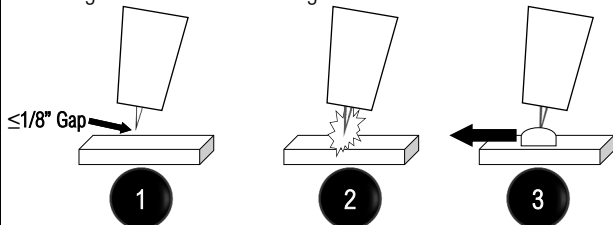

How Do I Perform a Lift Start?

1. Rest the edge of the cup on the work piece so that the tungsten is slightly off the work. Press the trigger or foot pedal. Quickly rotate the tungsten to the work using the cup edge as a pivot.
2. A small spark may be noticed as it touches. Once the Tungsten touches, quickly and seamlessly rotate the cup back to draw an arc.
3. Raise the cup to establish the arc to 1/8" or less in height.
4. Allow the puddle to form and move the torch forward maintaining 1/8 or less height.

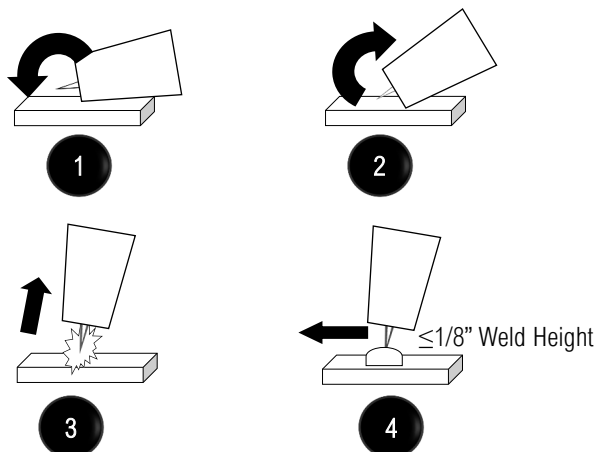

Remote Function and Operation.

Both HF Start and Lift Start mode on this Typhoon TIG welder need either a torch switch, a foot pedal (or similar Amp-trol mounted on the torch handle), or a torch with both a mounted switch and a separate torch switch button for special remote modes. *However, the Live Lift function requires no remote to start the arc since the Tungsten is always live.* The Lift Start with a remote switch or control provides a safe and effective means of starting the arc without HF while still being able to the weld with either the pre-programmed settings offered by the Remote 2T/4T type of control with a torch switch or with a foot pedal to control both start and the range of Amperage selected. When used normally with the foot pedal or torch mounted Slider Amp Control, the Remote function should be set only to the Pedal mode. **When the Pedal mode is used, many of the parameter/graph line functions will be nullified due to conflicts with proper pedal operation and function.** These nullified parameters will be items such as Up Slope, Down Slope and End Amps. *If the parameter is nullified, it is not adjustable. The nullified parameter will be grayed out and listed as Not Available (N/A).* Each available parameter can be adjusted and fine tuned

Component Identification and Explanation

TIG Arc Starting, Remote Functions and Operation

by the user so that each phase of the weld cycle can be controlled by the user. The torch switch allows several possible choices for Remote settings. The Remote setting that you select directly affects the way the torch switch interacts with the weld cycle. It can also affect the level of control and comfort provided. Each up or down movement of the torch switch triggers the next phase of the weld cycle. *The information below relates to how the weld cycle is controlled by each remote setting. Use the arrows as a guide to determine the movement direction that is necessary. The down arrow indicates that the torch switch should be pressed down. Do not release the torch switch until an up arrow is shown. If a down and up arrow are side by side, press and release deliberately with a slight, <0.5 second pause.*

The 4T Cycle provides a significantly finer level of control over the different stages of the weld cycle. This is accomplished by pressing down on the torch switch to start the first phase of the weld cycle. The switch will be held down until the user is ready to cycle the next phase. The switch is released to start the next phase of the weld cycle.

2T Operation

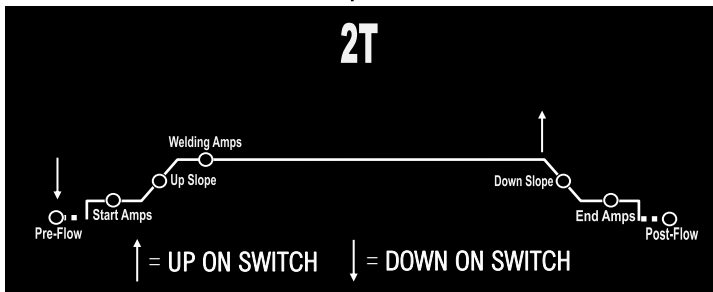

The 2T operation is the simplest operation. The torch switch is simply held down to start the arc, then released to down slope and terminate the arc.

2TS Operation

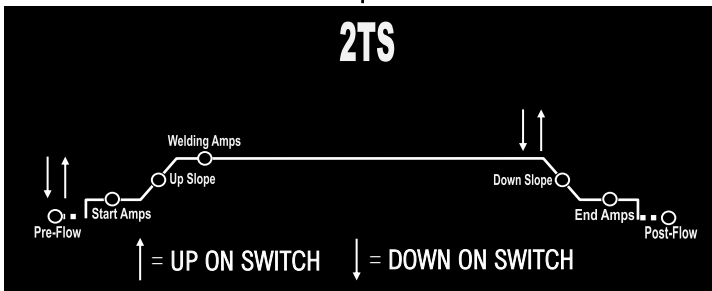

The 2TS operation allows the user to weld without having to hold the trigger down. The torch is pressed and released to initiate the arc and again to terminate the arc. Remember to pause slightly between Down/Up motions. *You may repress and release the trigger in the Down-Slope mode, before the arc is terminated, if you wish to cycle back to the Welding Amps phase.*

4T Operation

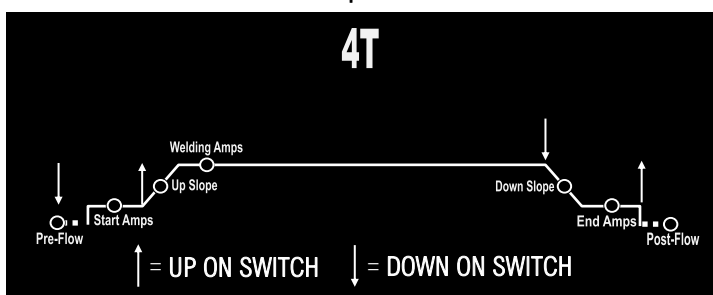

4TS Operation

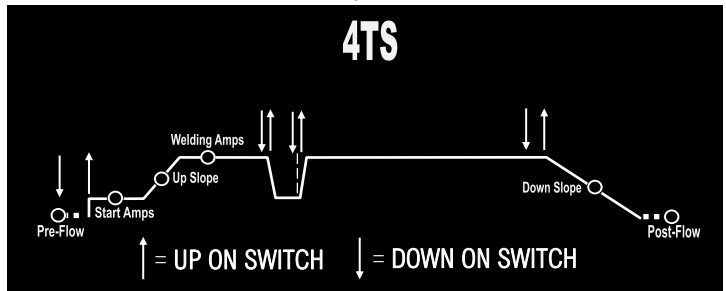

The 4TS Cycle also provides the high level of control over the weld function. The main difference between 4T and 4TS is that the switch is used to toggle between the Welding Amps and Start Amp level multiple times, until the user is ready to terminate the arc. In this mode, by pressing and holding the switch down until the down slope cycle is complete the arc will self terminate. The ability to cycle the back and forth between welding Amps and Down slope helps the user to modulate the amperage up and down to prevent burn through without the use of a foot pedal. *In this mode, the switch is not initially released until the user decides the post flow cycle is finished. In the final down slope and termination phase, the torch switch is held down until the arc terminates and the post-flow begins. End Amps are unavailable due to the complete arc tail out feature necessary for this function to terminate the arc.*

2T + Amp/ 4T + Amp (Hybrid Torch) Operation

These two modes (older models used 2T+Finger/4T+ Finger designations) operate the same way as 2T and 4T modes, but allow the use of the rolling amp control function of the special torch offered by Everlast. Since the 2T/4T operation has been covered, the operation is not illustrated. The + Amp settings allow a hybrid operation and give the user finger tip control of the amperage while welding and allows the user to set the welding amperage at the torch instead of walking back to the machine. Amperage can be modulated up and down while using this torch, but it is only to vary the heat and fine tune while welding, not a complete roll up or down of the heat as would occur with a foot pedal. In the 2T + Amp setting, it is better to use it to make major amperage modifications *before or after* welding, since the torch switch will need to be held down while welding and manipulation can be difficult. In the 4T + Amp setting, the torch Amperage can be rolled up and down after the pre programmed start occurs and the welding phase is initiated by releasing the torch switch.

Component Identification and Explanation

Explanation of TIG Parameters, Functions and Welding Terms

Alternating Current (AC). Used in TIG mode on this welder to weld Aluminum and Magnesium. It is composed of the flow of electrons rapidly alternating between Electrode Negative and Electrode Positive polarity.

AC Balance. Used to weld Aluminum and Magnesium, the AC wave form is formed by alternating the arc polarity rapidly between the electrode negative and electrode positive poles which changes the flow direction of the electrons. The electrode negative portion of the wave form provides most of the penetration and heat that goes into the weld. The Electrode positive portion imparts a smaller amount of heat to the weld as the flow of electrons travels from the puddle to the Tungsten. However, the Electrode Positive phase of the cycle does provide a scouring action which cleans the weld by removing the oxide layer by literally breaking and ripping up the oxidation, leaving an etched area under the weld puddle area and along the sides of the weld. If the two wave form halves are equal in length this means an equal time is spent between the positive and negative phases of the AC cycle. Even though cleaning is needed, there are problems with AC positive polarity. When the AC cycle enters the positive polarity phase, excess heat builds up on the Tungsten and it begins to ball due to electrons flowing from the weld to the tungsten. Little heat is put back into the weld. Another issue is the excess cleaning can occur and the weld will have wide areas of etching (cleaning) on the sides of the weld, which are generally undesirable. Some transformer welders were able to slightly skew the "balance" of the wave form, making one "half" of the wave form longer than the other "half". In other words instead of having a 50/50 balance, they were able to create a 40/60 balance, but this adjustment was limited. With modern inverters, the wave forms are much more adjustable and the balance has even greater adjustment range. In testing even with 5% Electrode Positive can provide enough cleaning to weld, while the other 95% of the arc energy can be put into heating the weld and providing penetration. The ability to adjust the balanced between the positive and negative cycles allows more penetration with less amps, narrower, less unsightly cleaning lines, and the ability to weld without a ball on the end of the tungsten. With the ability to weld without a ball on the tungsten, the arc stays more stable, and is focused more back into the weld. **The range on this unit is expressed as a percent of AC positive, with the idea in mind that "full" AC cleaning is 100% Electrode Positive and 0% electrode negative.** Some brands express this with a reciprocal value of Electrode Negative. So what would be a "safe" 30% electrode positive setting on the Everlast, becomes a 70% electrode negative setting on other brands. Everlast, along with other brands has chosen this way polarity orientation since the amount of cleaning is always discussed as a primary concern when welding aluminum. Increasing over 40% on AC balance will cause tungsten to begin to ball. There are legitimate reasons for welding over 40%, as in when the plate is heavily contaminated or oxidized, but if you need over 40% cleaning, you will need to change to a larger tungsten that will hold the point better. Once the tungsten begins to ball excessively, the arc will begin to wander or may break up completely. Signs of too little cleaning action while welding aluminum include soot, porosity, and dull looking (scummy) welds. *A dedicated stainless-steel brush and suitable aluminum cleaner such as acetone should be used before starting any aluminum*

weld to help break up the heaviest oxide layer so less Positive polarity cleaning action is needed and better penetration can be achieved by using more Negative polarity during one complete AC cycle.

What is AC Balance?

See the example below on how the AC balance functions. Keep in mind the AC balance of this welder is a percent of Positive Polarity. A setting of 30%, would be 30% cleaning, and 70% penetration.

AC Wave Form Balanced to 50/50 (Not Ideal)

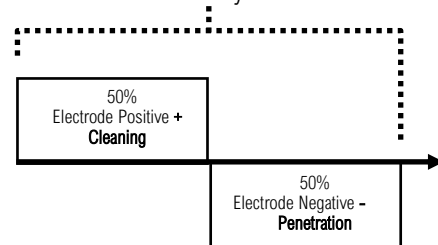

AC Wave Form Skewed to 30/70 (Typical)

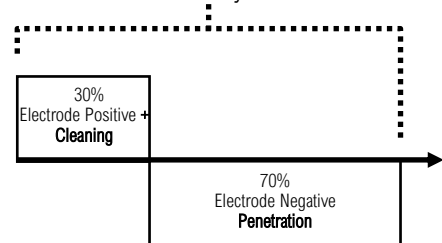

What is the effect of AC Balance?

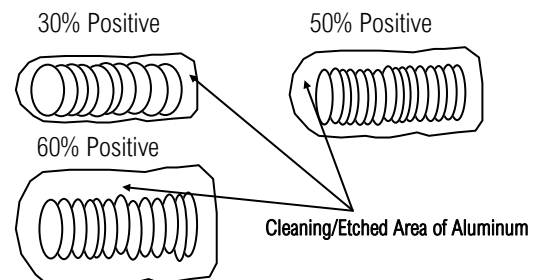

Symptoms of too much Positive Balance: Tungsten balling, wide etched area, grainy weld. Arc instability can become an issue as well.

What Balance Setting is Best?

Start with an AC balance setting of 25 to 35%. This will offer a good compromise between cleaning and penetration. Rarely exceed 40%. 35-40% would be a setting used on dirty cast Aluminum or heavily oxidized material that may have been subjected to salt water previously. Settings above 45% will begin to significantly ball the tungsten and cause arc instability. Maximum setting may cause the Tungsten to erode rapidly.

Component Identification and Explanation

Explanation of TIG Parameters, Functions and Welding Terms

AC Frequency. AC frequency is the number of times per second that the AC completely cycles between positive and negative polarity. Frequency is measured in Hertz (Hz). One full AC cycle equals 1 Hertz. Standard transformer welders typically have a fixed frequency of 60 Hz (North American market, other regions can be 50 Hz). This is because 60Hz is the standard input frequency from the power company. Transformer welders can only transform voltage and not the frequency of the voltage. The frequency that is input into the transformer will be the frequency that is output at the torch, even though voltage is transformed. In contrast, Inverter welders have the ability to change AC output frequency, despite the input frequency of the voltage. This unit has the ability to control AC frequency from 20 to 400Hz. When operating at lower AC output frequency, the arc is wide and lazy, but puts more heat into the weld. Operating at higher frequency focuses the arc, and pinpoints the heat into a narrower area. Higher frequencies allow better arc focus, *but* it may slow forward travel speed and may increase the Amperage requirement to weld the same part.

What Does AC Frequency Control Do?

By increasing or decreasing frequency, the AC Frequency controls arc cone width, overall heat input, travel speed, and directability of the arc while welding in AC mode. See the illustration below for how AC frequency affects the weld.

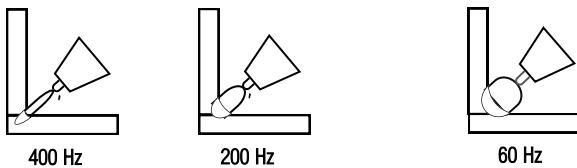

What AC Frequency is Best?

There is no one perfect frequency to use in all circumstances. However, most people agree that frequencies between 90 and 120Hz tend to be a go-to frequency range for most general purpose welding. Of course, higher frequencies may be used in areas where extreme control and pinpoint accuracy is needed. Lower frequencies will vibrate the puddle though, and give great cleaning action, although below 50Hz the arc may feel rough and ragged.

AC Independent Amplitude. The AC Independent Amplitude technology of the Typhoon adds another dimension of control by allowing Electrode Negative (EN-) Amperage and Electrode Positive (EP+) Amperage to be controlled independently. It has been discovered that suitable cleaning action can still be maintained with proportionally lower EP+ Amperage. This allows the user to deliver more heat to the weld while reducing the heat stress on the Tungsten. Reducing heat on the Tungsten extends the resharpen times while delivering more heat to the weld improves travel efficiency. It also helps by focusing the arc cone further AC Frequency can do by itself. With proportionally more ravel speeds can be increased over 50% while causing less wear on the Tungsten. The AC independent Amplitude allows the user to assign separate EN- and EP+ Amperage values.

When combined with ideal AC Balance Control settings, the synergistic effect of both working together can greatly extend the capability of this welder well beyond the range of traditionally configured TIG welders with basic Amperage control. This unit uses EN- as the anchor point for adjusting EP+. **EP+ Amperage is adjusted as a percent of EN- current.** The EP+ current can be adjusted anywhere from 10 to 125% of EN- Amperage. The reason the maximum Electrode Positive range is limited to 125% is that settings greater than 125% it will compromise arc focus, stability and travel speed. It will also increase the heat of the Tungsten, causing the consumption rate of the Tungsten to increase significantly.

What is Independent Amplitude?

The Independent Amplitude Control of this unit assigns an independent Amperage for both EN- and EP+ portion of the AC Wave shape. Below is a graphical example of what happens when AC Balance is combined with Independent Amplitude. Notice the graph scale is heavily weighted to the Electrode Negative as percent of time and Amperage in one AC Cycle. This example is designed to provide cleaning, but greatly improves penetration while reducing heat on the Tungsten. *Not to scale, exaggerated to show differences.*

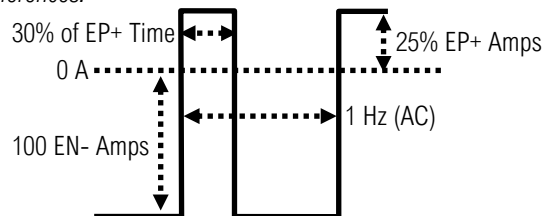

What Amplitude Setting is Best?

Keep in mind that most welders do not offer this setting which would put the Electrode Positive (EP+) Amplitude at 100% of Electrode Negative (EN-). This is a perfectly workable setting and the machine can be used this way in simplified form with the Amplitude turned "Off" or with EP+ set to 100% (which is the equivalent of turning Amplitude off, while still having access to the Amplitude function). But if it is used, consider moderate ranges of EP+ Amperage in the range of 25 to 75% to give good control and effect over the weld puddle and Tungsten. Settings over 100% EP+ are possible to offer greater cleaning effect but the arc cone will spread, travel speed will slow and the Tungsten may erode more quickly.

Amps. Shortened from "Amperes." Amps is a measurable value of Current. Amperage is used to refer to the magnitude of Current.

Direct Current (DC). Used to describe one way flow of electrons. Used in TIG to weld Steel, Stainless Steel (Inox), Chrome Moly, Titanium, and more. Not used with Aluminum and Magnesium.

Down Slope. Downslope is the duration of time that it takes for the programming to transition the Amperage from the Welding Amp (or Electrode Negative Amps if Independent Amplitude is selected) to the End Amp setting. Adjustment in Pedal mode will be blocked. This timer controls the

Component Identification and Explanation

Explanation of TIG Parameters, Functions and Welding Terms

decrease of the amperage and provides a window to fill the crater as the puddle begins to cool before the arc terminates. Used with all remote functions except the foot pedal.

End Amps. This is the destination current value set for the end of the weld cycle. When used with the torch switch, this is the final current set used to taper off and fill the crater at the end of the weld. For foot pedal use, this value should be kept at a minimum for proper tail off. However, the Tungsten size will ultimately dictate the exact minimum Amperage that a stable tail off of Amperage can be performed.

Gas Purge. This function is useful for setting and testing the gas flow rate. It activates the solenoid and opens it up so that gas can flow freely without having to fire the torch. It should always be used instead of firing the torch to activate the solenoid. The LED will stay lit until it is deactivated. It can also be used as a diagnostic to test gas solenoid valve operation.

High Frequency Start (HF). Depicted as HF on the menu screen under the start function, this is a touchless type of start. It is actually an simulated HF electronic controlled start, but due to the familiarity of users with HF, it is labeled as such to avoid confusion. When HF start is selected, the user positions the torch 1/8" or less above the weld area and either presses the foot pedal or the torch switch and the arc will jump. This HF start is created by a HV electronic system, instead of the traditional point gap design. A high voltage, low amperage current is created which jumps from the Tungsten to the work piece when activated. Once the machine sends a High Voltage impulse to the torch, the HV energy jumps the gap between the electrode and the work piece. Then, the welding arc will initiate after continuity is established. When continuity is established, the HF/HV shuts off. On this unit the HF/HV parameters can be programmed in the back ground menu. The length of HV start attempt, the strength of the HV arc and the HV impulse Amperage can all be set in the background menu. Once set, these parameters will seldom be changed. If the arc attempts to start longer than the set time, an error code "E05" will be displayed temporarily, meaning the switch is either stuck closed, or the arc has been activated too long without an arc start. This helps prevent damage to the machine and chance of accidental shock to the user. Do not "air fire" with the pedal or torch switch unless testing functions. Use the gas purge to set gas flow rate instead of firing the torch. The arc should only be used to strike an arc against the work piece.

NOTICE:

The HF on an inverter is not continuous. Formerly the term "HF" was synonymous with AC welding as it was required continuously to help stabilize the arc on a transformer welder since switching time in AC was so slow. The two terms were often confused used interchangeably. Inverter switching frequencies are so rapid that the need for continuous HF overlay is eliminated. HF now refers to the HV arc start.

Lift Start. Lift start requires touchdown and lifting up of the Tungsten to start the Arc. It is usually used only with DC output since some contamination of the tungsten is possible. But it can also be used with AC where HF

energy is prohibited, such as in a hospital environment. *There are two types of Lift Start that this unit has.* The first is a live lift start. This means the tungsten is always electrically live until the arc is started. When the tungsten is touched to the metal, continuity is sensed and the welder sends welding power as soon as the continuity is broken. If you need this type of start on a welder, contact Everlast for other product information. The other type of lift start is a "remote lift start". It functions essentially the same except, the tungsten is not electrically live and the torch switch or foot pedal must be used to make the torch live. This is a safer form of lift start and helps prevent accidental starting of the arc. It also means that the start type can be used with the welder programming in 2T and 4T mode, or with the foot pedal.

Post Flow. Post Flow is the amount of time (in seconds) that the shielding gas flows after the arc is terminated. This is an important function. The flow of shielding gas after welding is stopped helps to 1) Cool the torch and tungsten and prevents oxidation of the tungsten as it cools. 2) Provide cooling and shielding while the weld puddle solidifies and cools. This helps to prevent the weld from forming porosity and prevents oxidation of the weld as it cools. Post Flow should be increased at the Amperage increases. **For simple calculation, add one second of Post Flow for every 15 to 25 Amps used. At a minimum, 2 to 3 seconds should always be used.** To properly use Post Flow, the torch should be held in place over the weld after termination until the gas shuts off.

Pre Flow. Pre Flow is the amount of time (in seconds) that the shielding gas flows before the weld starts. It is very important that the Pre Flow be set for at least a short flow before any weld. The Pre-Flow not only purges the torch of any contamination, but it also establishes a protective envelope of shielding gas around the weld before the arc initializes. This protects the tungsten, and helps to establish an arc more quickly by surrounding the tungsten and work with more easily ionized gas so that arc starts are more efficient. It also allows time for the gas flow to stabilize before the arc is struck. When initializing the Pre Flow a "rush" of gas can often be heard just ahead of the arc strike. Then the gas flow will quieten down as the weld begins. This is normal. This rush of gas is caused by several things, but it is in part due to regulator attempting to regulate the sudden rush of gas. As it does this, extra gas may be consumed until the regulator has had time to react. The extra flow of gas may create turbulence around the weld. The Gas flow rate may also temporarily increase due to the back pressure "ballooning" of the gas lines. As the slightly swollen gas lines stabilize, extra gas is propelled as the solenoid opens relieving the back pressure. Using .3 to .7 seconds is usually enough to allow the "gas rush" to stabilize, unless extra large shielding cups are used. If over-sized cups are used (≥ 10), increase to 1 to 2 seconds.

NOTICE:

The arc start will be delayed by the amount of time chosen for Pre Flow. If Pre Flow is set for 2 seconds, the arc will not start for 2 seconds. This is sometimes easy to forget, especially when tacking or "Bump" welding.

Component Identification and Explanation

Explanation of TIG Parameters, Functions and Welding Terms

PowerSet. The Typhoon series of welders offer a unique power set menu mode that allows the user to input several operating parameters such as Tungsten Diameter, Metal type, and even joint type. In return the unit will provide a usable range of Amperage. It will limit and preset most all other parameters and functions so that the user doesn't have to go through an extensive set-up routine. AC frequency, AC balance, pre-flow/post-flow, and other similar parameters and functions will be set for the user. The PowerSet mode also offers 10 levels of a profiled pulse, each with different and increasing pulse frequencies. The basic Pulse parameters are fixed so that consistent results can be achieved without having to worry about additional adjustment of settings.

Pulse. The TIG pulse creates two amp values, a high and a low value that cycle back and forth between each other while welding. This helps preserve travel speed while reducing the size of the Heat Affected Zone (HAZ). The pulse is divided in to two phases or stages. The upper amperage phase is called Welding Amps, which is sometimes referred to as Peak current. When Independent Amplitude is selected, the Electrode Negative location serves as the High Amp "Peak" phase of the pulse. The lower amperage phase is called "Pulse Amps" (sometimes called "background" or "base" current). The Pulse Amps are set as a percent value of Welding Amps/Electrode Negative. Pulse has several uses and can be used to control arc directability, arc cone width, heat spread, penetration, travel speed and even weld appearance. It is particularly useful on metals that are prone to structural deterioration from the HAZ or burn through. Pulse is used strategically to create a lower average Amperage, by varying one or more of several adjustable pulse parameters to reduce heat input.

- 1. Pulse Amps (Base).** Base Amps is the low Amperage value of the pulse. When you adjust the base Amps in pulse mode, you are actually setting a ratio of base Amps to peak welding Amps. Base amps are expressed as a percentage of Peak welding Amps. So, when you set base amps, you are only setting it as a percentage, not the actual Amps. As you increase Peak welding Amperage through the use of the foot pedal, or the panel control, the pulse will maintain the same ratio of Base to Peak welding Amps, raising the base Amps automatically. To illustrate: Adjust the Peak (main welding) Amps, to 100. Set the base Amps to 50%. This will yield a 50 Amp value for the base Amps. The foot pedal controls both Peak welding Amperage and Base Pulse Amperage simultaneously, using the pre-set ratio. *For Adv. AC Pulse, this is the DC portion of the Pulse.*
- 2. Pulse Frequency (Hz).** Pulse speed is referred to as Frequency, which is measured in Hertz. Pulse frequency controls the arc constriction and also helps with heat management. A slower pulse frequency around 1 to 3 hertz gives the "stacked dime" appearance. At higher frequencies the "stacked" appearance will be lost while heat control is increased. This is also referred to as "Pulses Per Second" or "PPS".
- 3. Pulse Time On (Balance/Duty Cycle).** Pulse Balance is the percentage (%) of time that the pulse stays in the TIG (Peak) pulse Amp phase of the cycle. Increasing the Pulse time-on will increase the

duration the Peak Amp phase of the cycle which in turn will increase the heat and will increase penetration. Pulse Balance is also known in the industry as "duty cycle". For TIG welding purposes the term "Pulse Time On" is used here.

- 4. Pulse Wave Form (DC Only).** Due to the digitally controlled inverter's capability, the pulse wave form can be shaped into 4 different wave shapes to offer more control and to soften the sound of the pulsing arc. The panel menu allows you to select different shapes on the weld cycle graph line to represent the different wave forms.
 - **Advanced Square.** This is the most dynamic and aggressive wave form that will offer maximum puddle agitation and fast freezing puddle. This is the loudest of all the pulses, but

Is There a Better Way to Understand Pulse?

Pulse is essentially a wave form created by the pulsing amperage. This wave form can be skewed, expanded, compressed, increased or decreased in magnitude. Each change in Amps, Pulse Time On Balance, and Frequency all affect average heat being put into the weld. The examples below attempt to explain the parts of the pulse and how each part of the pulse functions. *Examples not to scale.*

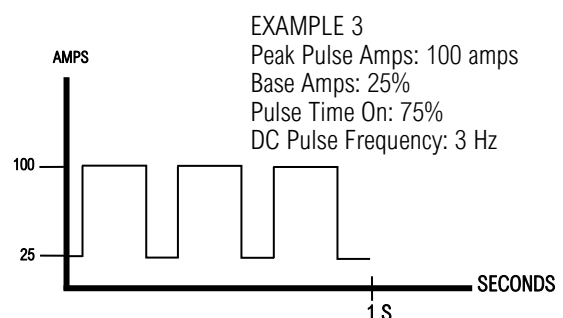
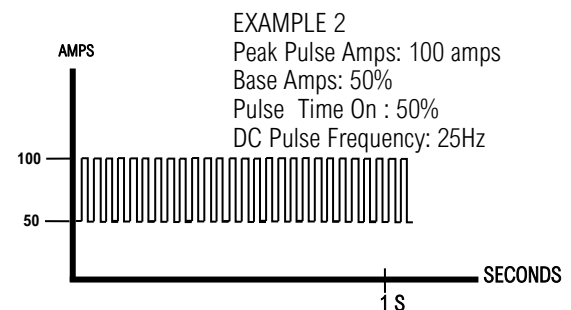
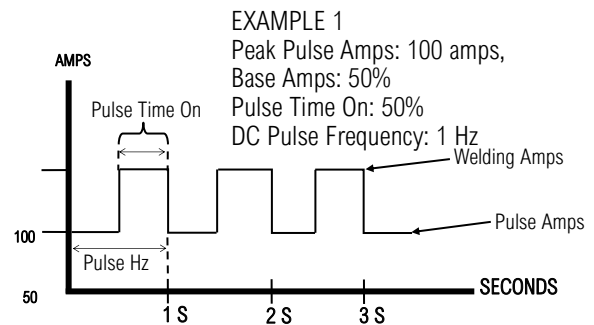

Component Identification and Explanation

Explanation of TIG Parameters, Functions and Welding Terms

does a good job on heat management. Represented by a square ■ on the graph line.

- Trapezoidal. This wave form is a softer version of the Square, and still offers good freeze, but reduces the aggressiveness of agitation. It creates a lower, softer tone when compared to Adv. Square wave DC pulse. Represented by a trapezoid ▭ on the graph line.
- Triangle. This wave form offers maximum control over heat input by offering the slowest transitions between Amperages, which in time offers a more rapid wet-in and gives the quietest sound. Represented by a triangle ▲ on the graph line.
- Sine. This is a well rounded pulse which offers smooth transitions between the peak and base currents, with a gentle fluid feel and moderate sound. Represented by a semi-circle ◐ on the graph line.

Setting up TIG pulse is not a one-size-fits-all process. There's no template or list of settings that can be offered to the user that will work in all situations. It's very difficult to offer pulse setting lists for even well-defined applications. Even though the PowerSet menu does offer a preset functions for pulse, it still gives 10 choices to choose from so the user to select the best operation. Even then none of them may be suitable for the user, depending upon personal preferences, skill and understanding of the pulse. Changes to any one pulse parameter, whether it be frequency, balance or Amperage will skew the effect of the pulse. Keep this in mind when making changes and make only small changes to one parameter at a time to dial in the desired effect.

A slow pulse between .7 and 2.5 Hz with an equal 50% pulse time on and somewhere around a 30-60% Pulse Amp setting can be used to help with timing the addition of filler metal to the weld puddle. This type of setting will improve bead appearance. A high pulse frequency that is combined with complimentary settings of 50% or below Pulse Time On and a low pulse Amps settings of 40% or below can be used to prevent burn through and speed up welding on thin materials. It can also help maintain a proper bead profile on a thin edge weld or prevent burn through on extremely thin metal. A fast pulse speed will make fine ripples in the weld while a slow pulse speed will give a much more coarse, but visually appealing result. There are limitless ways to adjust the pulse. Regardless of how you choose to adjust the pulse, always keep in mind, that the basic purpose of the pulse is to average the heat input while maintaining penetration and welding speed.

AC Pulse TIG operation setup is the same. Do not confuse alternating polarity between Electrode Positive and Electrode Negative as pulse. It is not. You are still adjusting the amperage of the AC pulse, and skewing the balance and changing the frequency similarly to the DC pulse.

In Advanced AC mode, this is a "mix" mode of actual AC and DC current,

where each pulse cycle contains both AC and DC current. This can be used to greatly increase the welding range (and penetration) of the welder by up to 50% or more while welding Aluminum. The AC portion of the pulse (when properly adjusted) provides adequate cleaning action, in front of the DC portion of the cycle which comes on to provide penetration in the area just cleaned. It can also be used to adjust bead profile and even tungsten life, in the hands of an experienced user. The AC phase of the pulse cycle is assigned to the Peak Welding Amps (or Electrode Negative if the Independent Amplitude is activated) portion of the cycle. The DC portion of the pulse cycle is assigned to the "Base" Pulse Amps of the Cycle. The AC phase of the pulse is set in actual amps, whereas the DC portion of the cycle is set as a "percent" of the AC welding Amps. Increasing the percentage (%) of DC Pulse to AC welding Amps increases penetration. For maximum penetration and power, set DC to 100%. The Pulse time on and frequency act the same as in standard pulse, but when fine tuning, the Pulse Time on is used to adjust the total amount of cleaning given to the weld area before the DC portion of the pulse cycles on. Frequency can be adjusted for welding speed needed and to establish a more steady transition between AC and DC portions of the pulse cycles. The initial use of this mode may be disconcerting as the constant "on/off" nature of the Buzz may be heard. Timing of the addition of the filler rod may be also thrown off initially, but with practice, this feature can be used as a valuable tool. When DC is adjusted to a low % setting, while welding on thin metals, the bead profile will change and additional control will be given.

What Are The Adv. AC Pulse Components?

Advanced AC Pulse is a mix of both AC and DC. This type of pulse is designed to increase weld capability in AC mode up to 50%. The DC, which is in the Pulse Amps location can be set up to 100% of the AC (or 100% of EN Amp value if Independent Amplitude is active) to provide a powerful alternating punch. The AC side of the pulse scours the surface ahead of the DC "hit" of the pulse, so the DC Amperage is punching through cleaned metal. This type of pulse can also be used on thin metals to achieve improved bead shapes when DC Amps is turned down. Adv. AC pulse offers interesting possibilities of increased performance. Combined with Independent Amplitude, it shows promise to completely change the normal accepted Amperage capability limits of AC welding.

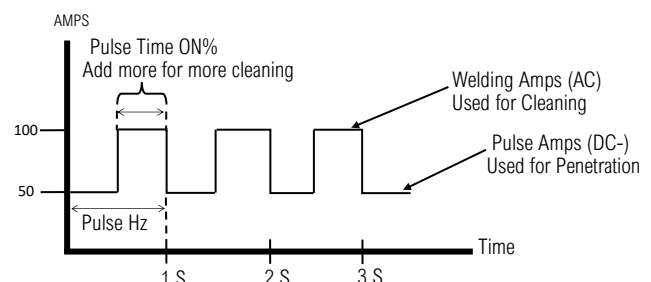

Regulator./Flow Meter Controls the flow rate of the shielding gas at the

Component Identification and Explanation

Explanation of TIG Parameters, Functions and Welding Terms

cylinder. The regulator should never be left turned on. Leaks can and do develop over time or suddenly. Gas solenoids can fail to close properly. Whenever a regulator is not in use, the pressure should be relieved so that the diaphragm/spring will not prematurely fail or lose accuracy.

CAUTION: *Always open the regulator slowly, while standing to the side so that if it were to fail parts will be ejected away from you. Never stand over a regulator while opening.*

Remote. Remote refers to the ability to start the arc and control the weld cycle at a distance. High Frequency Start must be used with a remote to operate. Lift Start can also be used with a Remote. A remote can be a foot pedal, torch switch, torch mounted slider or hybrid Amp-trol torch. All of them are used to start and end the arc as well as control other parts of the

weld cycle to varying extents. The unit has multiple Remote settings to choose from. 2T/2TS/4T/4TS settings all must be used with a remote switch. Pedal mode is reserved for use with a Foot pedal or slider Amp control mounted on the torch handle. The hybrid torch switch/amp-trol must be used with the special 2T+ Amp and 4T+ Amp controls (formerly 2T+Finger/4T+Finger).

Pedal mode is the most straight forward. Operation is quite simple. The maximum amperage is set on the panel. Then the foot pedal is used to start and stop the arc as well as vary the amperage from the minimum welding setting, up to the maximum welding setting selected on the panel. When used in pedal mode, many weld cycle parameters will not be available for adjustment since the pedal itself controls those functions manually.

Shielding Gas. Shielding Gas is necessary while TIG welding. The shielding gas used for the TIG process is 100% Argon. Shielding gas protects the weld from oxidation by the atmosphere while the weld puddle is still molten. Gas flow rates are controlled by the supplied regulator. Too little gas flow will cause porosity, heavy scale and or oxidation. Too much gas flow is wasteful and can also create a turbulent flow, which can pull the atmosphere into the weld, creating oxidation. *See suggested flow rates.*

Start Amps. This is the initial Amperage of the weld in TIG mode. This is the starting point, at which the arc initiates. The Start Amps are sometimes confused with the surge amperage required to start the arc. These are separate items. The surge amperage (which all TIG welders have, whether it's published on the screen or not) is a micro surge of Amperage required to establish the arc lasting only milliseconds. Start Amperage is the actual Amps at which the arc will establish itself as it stabilizes. It becomes particularly effective when using the torch switch for welding aluminum by allowing a more rapid wet in at the beginning of the weld. For larger diameter tungsten, the Start Amps can be increased to provide a more stable low end start with the foot pedal. The Tungsten size function dictates the minimum Starting Amperage so that the best start can be obtained. However, it is not the absolute lowest limit. To obtain complete control over the Start Amp parameter, set the Tungsten function to "Manual." Start Amps may be set higher than the Welding Amperage, but more rapid wear of the Tungsten may result.

Spot Weld Timer/ Fast-Tack. The Spot weld timer simply is an Arc-On timer for TIG welding calibrated in tenths of a second. The use is intended to help the user to create better tack welds with improved consistency in size and penetration. Once the torch switch trigger is activated, the arc will stay turned on for the amount of time selected. After the time has expired, the welding arc will shut down. The Spot Timer can be used in both AC and DC modes. However, the Fast-Tack function (also referred to as "Cold-Weld" function) is only intended for DC use. It is designed for a shorter duration and is usually combined with an intense high current flash that will join thin gauge metals together. The Fast-Tack function adjusts in milliseconds rather than tenths of a second for a rapid blast of fusing heat. Normally Fast-Tack is used without filler metal. Spot may or may not be used with filler metal. Both Spot and Fast-Tack functions can only be used

Can I Use a Remote Wireless Pedal?

The Typhoon series is especially suited for use with the NOVA wireless pedal. It includes an outlet on the rear for the transmitter power. The metal case is suitable for attaching the magnetized transmitter as well. The rear outlet should only be used for powering the NOVA wireless pedal. Even though it appears to be a 15A outlet this is a low amp 240V/120V outlet designed for use with only this model pedal.

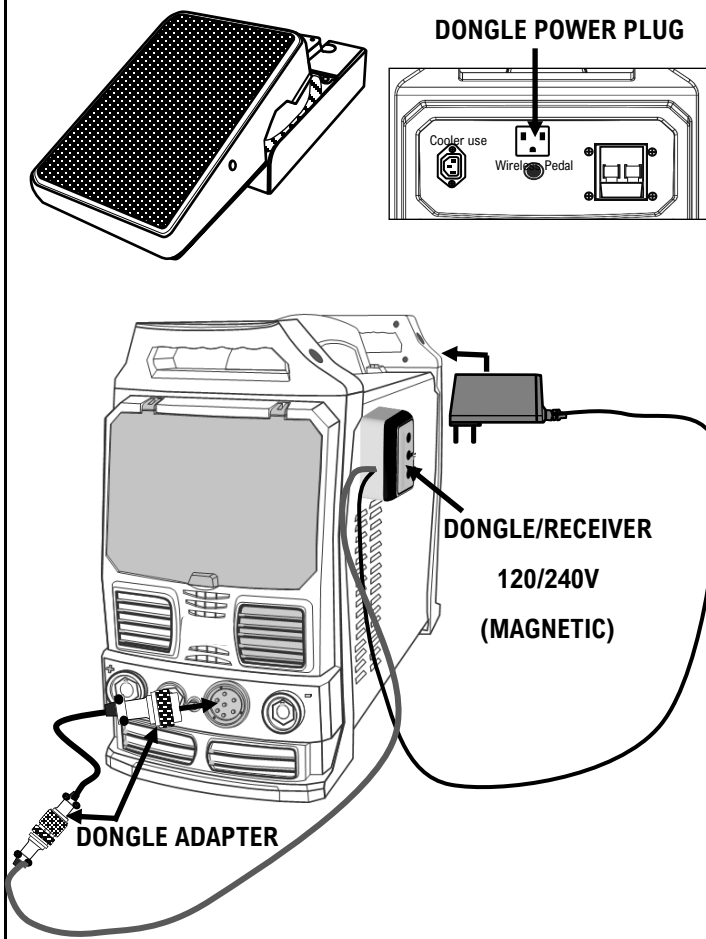

Component Identification and Explanation

Explanation of TIG Parameters, Functions and Welding Terms

with a torch switch. The settings will default to 2T and HF start. **This is not meant to be used with or serve as a controller for tong-type Spot welders.**

Stitch. The Stitch function can be used with both the Spot and Fast-Tack function. Whereas the Spot/Fast Tack function is a “Arc-On” timer, the Stitch timer is an “Arc-Off” timer which works if the switch is continually held. This creates a repeating on/off cycle that is useful for welding long seams of sheet metal, or creating regular sized spot welds along a object while tacking up for fitment. When used with Fast-Tack, this can be used to create a rapid succession of flash welds that help weld thin materials together with a fine, thin weld bead.

Split Wave Form Control. The welder can operate either with a balanced wave form where both halves of the AC cycle are set to the same wave form shape or with the wave form split into separate half-wave shapes. This split wave form control gives the user the ability to further improve performance and Tungsten life by mixing and matching half-wave forms shapes. It can also help quieten the arc without loosing the desired properties of the of the electrode negative phase of the wave form.

Up-Slope. Upslope is the duration in time that it takes for the programming to transition the Amperage from the Start Amp value to the Welding Amp (or Electrode Negative Amp if Independent Amplitude is active) value. If Start Amps are set higher than the Welding Amp values, then technically it will down slope to the Welding Amp value. However high start Amp values can increase Tungsten wear. Used with all remote functions except the foot pedal.

Wave Form Control (AC wave shape). This controls the shape of the wave-form that is created by the AC mode, as the arc cycles between electrode negative and electrode positive polarity. The wave form created by traditional power companies is considered to be a sine wave. This sine wave, when viewed on an oscilloscope is very smooth and regular, and even rounded at the peaks and valleys of the wave form. With an inverter welder, pre programmed wave forms can be generated. Each wave form has special weld properties and a different appearance on the oscilloscope. As a summary explanation:

Advanced Square Wave: This is the default wave form to be used in most situations. The shoulders and tops of the wave form are square, with an immediate transition between Electrode Negative and Electrode Positive half cycles of the AC wave form. This wave form introduces the most heat to the weld and provides the fastest wet in, but is the harshest overall. Arc stability and directability are excellent. In general though, use this wave form for most applications. If using the welder in a split wave form configuration, the Adv. AC offers a good base wave form for the Electrode Negative half-cycle for excellent penetration and wet in. In most, but not all cases, it would not be considered for running in the Electrode Positive half wave cycle in the split configuration. Use with Lanthanated Tungsten.

Soft Square Wave: This is a square-type wave form, with more rounded shoulders. This is the wave form generated by most transformer square-wave welders. It isn't as aggressive or as quick to wet in, but is a satisfac-

tory wave form to use when a balance between quick wet in and a generally buttery, but controllable weld. This is less likely to consume Tungsten as rapidly, but some “heat” loss going into the weld will be experienced. If used in the Split wave form configuration, it offers good utility when used with other wave forms on both EN- and EP+ sides of the wave form. Use with Lanthanated or Ceriated Tungsten.

Trapezoidal Wave: This is a unique wave form shape that is an exclusive wave form shape developed by Everlast to offer a new level of control to the user. The shape combines several of the best features of the Adv. Square wave and a Triangular wave form to create a forgiving, smooth arc that provide good wet-in and travel speed without the high noisy buzz of the Adv. AC wave form. It's a good choice for the Electrode Positive side of the wave form when splitting the wave form. Use with Lanthanated or Ceriated Tungsten for this wave form.

Triangular Wave: This wave form provides the least amount of heat and is used on thinner gauges of aluminum. This provides a longer lasting point, and a better bead profile on thin metal gauges. Due to the triangular shape of the wave form, the current only stays at the peaks/valleys a fraction of the time of any other wave form lower output amperage from what is set. The gradual transition of the wave form makes it the best wave form to use for welding thin gauge metals when used in a balanced wave form configuration. When used in the Split wave form configuration, it serves well on either the Electrode Positive or Electrode Negative side of the AC cycle. Use Lanthanated or Ceriated Tungsten for this wave form.

Sine Wave Form. This is the oldest and softest wave form used by transformer welders before square wave technology became available. Even though this is a wave form from the fast switching inverter, it provides a soft feel to the arc, but wet in times are relatively long. Arc directability, and stability in comparison is poor. Because this wave form is created by an inverter with fast switching times, the need for HF current overlay used to prevent arc outages (at 60 times a second) in old transformer type TIG welders has been eliminated. This arc is not the most easily controlled and directable, but may be a more comfortable wave form for users who transitions from older transformer welders using a balled Tungsten. When used in a split wave-form configuration, it is a good wave form to use on the EP+ side of the wave form. Use Lanthanated or Ceriated Tungsten for this wave form even if a slight ball is desired. Never use pure Tungsten.

Welding Amps. This is the main default current control. When used in the context of Pulse, this is the “Peak” part of the pulse while the Pulse Amps is the “Base Amp” part of the pulse. Without Pulse, the main welding amps simply controls the Amperage of the welder. When Independent Amplitude is selected, the unit defaults to the Electrode Negative Amp setting on the expanded graph line. The former location of Welding Amps then becomes the Electrode Positive Amp location. The Electrode Negative then serves as the *defacto* Welding Amp location and also serves as the Peak part of the Pulse when Independent Amplitude is activated. *For Advanced AC Pulse, this is the AC portion of the Pulse.*

Component Identification and Explanation

Explanation of Stick Parameters, Functions and Welding Terms

Alternating Current (AC). This is used in Stick mode to provide an alternative to DC when Arc blow and magnetism becomes a problem. It is composed of rapidly changing electrical polarity that constantly changes between Electrode Positive and Electrode Negative polarity. With this unit, this can happen up to 400 times in one second. This alternating polarity imparts special characteristics to the arc by making it less sensitive to magnetic fields and even wind. AC is not typically preferred because of high spatter and violence of the arc. It also requires more Amperage than DC to weld the same equivalent thickness because it provides shallower penetration. Unlike TIG, AC is not required for welding with Aluminum electrodes. DC positive (Reverse Polarity) should be used. However due to the advancements in inverter control, the Typhoon offers adjustable AC Balance and Frequency which can be an advantage when AC is required. When welding in AC, the machine should be operated with the Electrode Holder in the negative terminal. It should never be used with the Electrode Holder in the positive or overheating may occur.

AC Balance. The AC current can be divided up into Electrode Positive and Electrode Negative polarity. The amount of time that the unit spends in each phase of the AC cycle can be skewed toward the Positive or Negative polarity. The AC balance adjustment is adjusted as a percent of Electrode Positive Polarity. Typically you will want to have between 20 and 50% Electrode Positive.

AC Frequency. The number of times per second that the AC polarity changes from Negative to Positive completely is called AC Frequency. It is measured in Hertz (Hz). One Hertz equals one complete AC cycle. This unit can be adjusted from 20 to 400 Hz.

Anti-Stick. This is a special function that helps make removing stuck rods easier. When the mode is activated, the unit senses the low voltage output of the stuck rod and drops current to prevent the rod from sticking fast in the weld puddle, overheating and flaming out. The goal is to make releasing and removing the stuck rod easier so that it can be salvaged.

Arc Force. Arc force is used to offset the loss of overall wattage ($V \times A = W$) as the arc length is shortened and voltage begins to drop while stick welding with short arc conditions. It offsets the drop in voltage by injecting extra amps into the weld when voltage drops below the 20V threshold. This enables the amperage to react aggressively or mildly, depending upon settings. It also helps to prevent arc outages, and allows the user to hold a tight arc and maintain better control. This function is also referred to as "Dig" and "Inductance" in the industry. Arc force is set as a percent of Amps over the set welding Amps. As the welder nears the top end of the Amp rating for stick welding, Arc Force action will be reduced due to less compensating Amperage being available for use. This will happen regardless of Arc Force Setting. Typically Arc force settings with rods such as E7018 and E6013 should be set to around 20 to 35%. Arc force for Cellulose based Flux rods such as E6010 and E6011 is 60% or greater.

Direct Current (DC). This is the preferred method of stick welding. For most applications, the electrode holder will be connected to the Positive

terminal. The welder will remind you of this polarity. However, there are a few times where Electrode Negative may be used. To use electrode negative polarity, all you need to do is swap the electrode hold and work clamp positions so that the electrode holder is in the negative terminal. This will not harm the machine. Follow electrode manufacturer's recommendation for Polarity and Amperage range.

Hot Start Amps (Intensity). This setting controls the intensity of the arc start by boosting the initial amps at the start of the weld cycle. It is used to improve arc starting and reduce the time needed to establish a puddle and helps to prevent porosity at the beginning of the weld. The Hot Amps are set as a percent of Amperage over the welding Amps. Maximum Hot Start action may be limited by available Amperage for stick welding. As the current is raised near the top Amperage of the welder, Hot Start Action will be less forceful due to less Amperage being available, regardless of machine setting. Typical settings can be between 30 and 70%, depending on electrode type. Iron Powder and Low Hydrogen rods will require less Hot Start action from 30 to 50%. Cellulosic rods may require 60 to 75%.

How Do I Start an Arc With Stick?

There are two basic types of arc starting methods used. The tapping motion allows pin point placement of the arc, while the scratch start method is similar to a match strike and is easier for beginners.

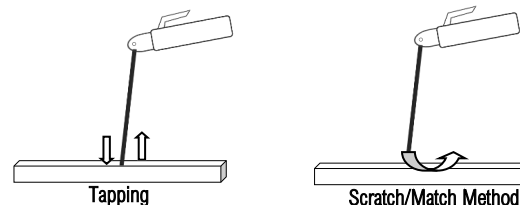

Hot Start Time (Duration). This is the time the Hot Start Stays engaged. The Hot Start Time will be increased on thicker plates, but in general, .5 to .7 seconds works well for plate thicknesses up to 3/8".

Open Circuit Voltage (OCV). OCV is the voltage that is present when the arc is not struck. This voltage is used to strike the arc. In general the higher the OCV, the easier it is to strike the Arc. The Typhoon series use a higher OCV for easy arc striking.

Remote Function. This unit supports the use of remote Amperage control. This means the foot pedal can be used to control stick Amperage, if needed. For more options, contact Everlast.

Reverse Polarity. This is the same as DC Electrode Positive Polarity (DCEP+). It is an older term that is still around that many welders use which can be confusing. However, this is the standard polarity used for DC stick welding.

Stick. In North America, this is the SMAW process (Shielded Metal Arc Welding) In other regions this is called MMA (Manual Metal Arc). Stick is an older term used to refer to the stick like appearance of the welding electrodes (also known as welding rods). This is a versatile process and

Component Identification and Explanation

Explanation of Stick Parameters, Functions and Welding Terms

can be used in adverse conditions where TIG cannot.

Straight Polarity. This is the same as DC Electrode Negative Polarity (DCEN-). It is an older term that is still around that many welders use which can be confusing. This is rarely used for DC Stick Welding. For AC TIG welding however, the torch should be electrode negative to be able to properly setup the unit. All TIG welding will be performed with the Torch negative, even in AC.

Voltage Reduction Device (VRD). This function reduces Open Circuit Voltage (OCV) while welding stick. This is required in some applications to comply with safety standards. This reduces high OCV down to 20V or less. This can also make arc starting slightly more difficult. A quick double tap can offset the hard starting. *See specifications on page 12 for OCV data to determine if the use of the VRD is required.*

Which Welding Rods Can I Use?

This welder is designed to weld with almost any welding rod on the market. It does have required Rod selection information for both Standard and PowerSet modes. However, that does not limit you to only the rods listed. Select the rod type that is closest to the welding rod that you are using in properties and characteristics. If you are not sure, then select E7018 for most rods, including Aluminum rods. Welding rods with Rutile and Titania based flux can be used with E7018 or E6013 settings (which ever gives the best performance or is nearest in composition to the rod choice available). This will provide excellent welding performance with most rods, including iron powder and fill/freeze types. For cellulosic types like 6011, 7010 and 8010, select the E6010 setting.

Component Identification and Explanation

9 Series Air-Cooled Welding Torch (Typical Type) Parts and Assembly. DC 125A @ 60% Duty Cycle; AC 90A @ 60% Duty Cycle

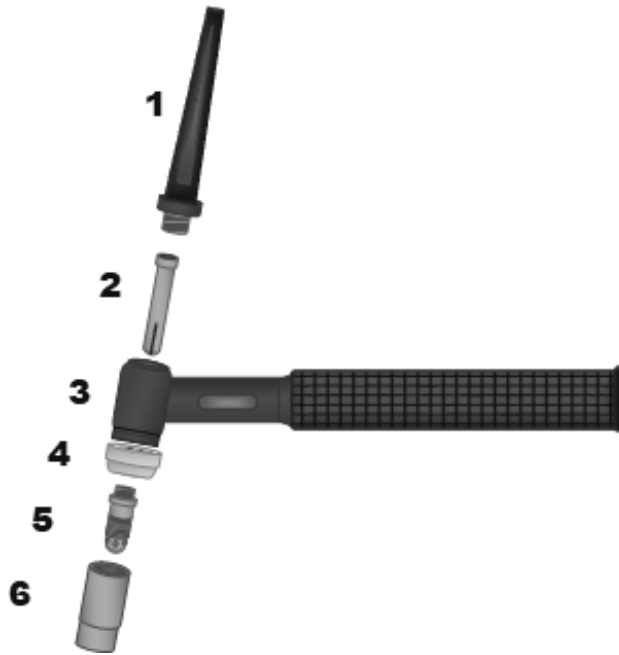

Typical Everlast and NOVA Torch Assembly (9/20 Series)

(Some parts may not appear exactly the same but are equal in assembly order and type.)

Tungsten not included, but available in select Consumable Kits on the website at www.everlastwelders.com.

Consumables are standard sized for series 2 torches, and interchange with consumables made for similar torches with similar nomenclature.

Drawing#	Description	Size/Type	Part#	Alternate Ref.	Note
1	Back Cap	Long	NVA-41V33	41V33	
1	Back Cap	Medium	NVA41V35-2	41V35	
1	Back Cap	Short	NVA41V24-2	41V24	
2	Collet	.040"	NVA13N21-2	13N21	1.0mm
2	Collet	1/16"	NVA13N22-2	13N22	1.6mm
2	Collet	3/32"	NVA13N23-2	13N23	2.4mm
2	Collet	1/8"	NVA13N24-2	13N24	3.2mm
3	Torch Body/Handle	9 or 20	Call for Application		Varies by Type
4	Heat Shield	9 or 20	NVA-HS920-2	Heat Shield	Interchanges with similar aftermarket
5	Collet Body	Universal one size fits 1/16" to 1/8"	Stock	Stock	Universal Collet Body and Collets supplied with original starter kit
5	Collet Body	.040"	NVA13N26-2	13N26	1.0mm, match to collet size
5	Collet Body	1/16"	NVA13N27-2	13N27	1.6mm, match to collet size
5	Collet Body	3/32"	NVA13N28-2	13N28	2.4mm, match to collet size
5	Collet Body	1/8"	NVA13N29-2	13N29	3.2mm, match to collet size
6	Cup	4	NVA13N08-2	13N08	Standard, non gas lens 1/4"
6	Cup	5	NVA13N09-2	13N09	Standard, non gas lens 5/16"
6	Cup	6	NVA13N10-2	13N10	Standard, non gas lens 3/8"
6	Cup	7	NVA13N11-2	13N11	Standard, non gas lens 7/16"
6	Cup	8	NVA13N12-2	13N12	Standard, non gas lens 1/2"

Component Identification and Explanation

20 Series Water-Cooled Welding Torch (Typical Type) Parts and Assembly. DC 250A @ 100% Duty Cycle; AC 200A @ 100% Duty Cycle

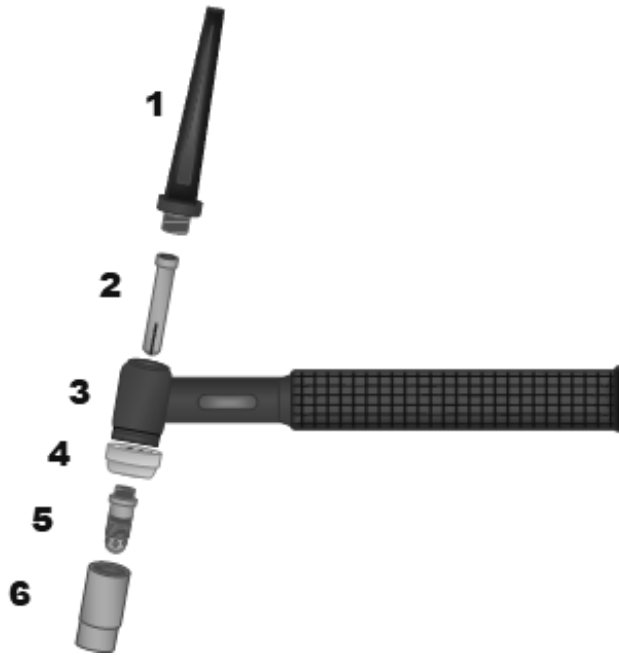

Typical Everlast and NOVA Torch Assembly (9/20 Series)

(Some parts may not appear exactly the same but are equal in assembly order and type.)

Tungsten not included, but available in select Consumable Kits on the website at www.everlastwelders.com.

Consumables are standard sized for series 2 torches, and interchange with consumables made for similar torches with similar nomenclature.

Drawing#	Description	Size/Type	Part#	Alternate Ref.	Note
1	Back Cap	Long	NVA-41V33	41V33	
1	Back Cap	Medium	NVA41V35-2	41V35	
1	Back Cap	Short	NVA41V24-2	41V24	
2	Collet	.040"	NVA13N21-2	13N21	1.0mm
2	Collet	1/16"	NVA13N22-2	13N22	1.6mm
2	Collet	3/32"	NVA13N23-2	13N23	2.4mm
2	Collet	1/8"	NVA13N24-2	13N24	3.2mm
3	Torch Body/Handle	9 or 20	Call for Application		Varies by Type
4	Heat Shield	9 or 20	NVA-HS920-2	Heat Shield	Interchanges with similar aftermarket
5	Collet Body	Universal one size fits 1/16" to 1/8"	Stock	Stock	Universal Collet Body and Collets supplied with original starter kit
5	Collet Body	.040"	NVA13N26-2	13N26	1.0mm, match to collet size
5	Collet Body	1/16"	NVA13N27-2	13N27	1.6mm, match to collet size
5	Collet Body	3/32"	NVA13N28-2	13N28	2.4mm, match to collet size
5	Collet Body	1/8"	NVA13N29-2	13N29	3.2mm, match to collet size
6	Cup	4	NVA13N08-2	13N08	Standard, non gas lens 1/4"
6	Cup	5	NVA13N09-2	13N09	Standard, non gas lens 5/16"
6	Cup	6	NVA13N10-2	13N10	Standard, non gas lens 3/8"
6	Cup	7	NVA13N11-2	13N11	Standard, non gas lens 7/16"
6	Cup	8	NVA13N12-2	13N12	Standard, non gas lens 1/2"

Component Identification and Explanation

7 PIN CONNECTOR FOR 10K Ω NOVA FOOT PEDAL

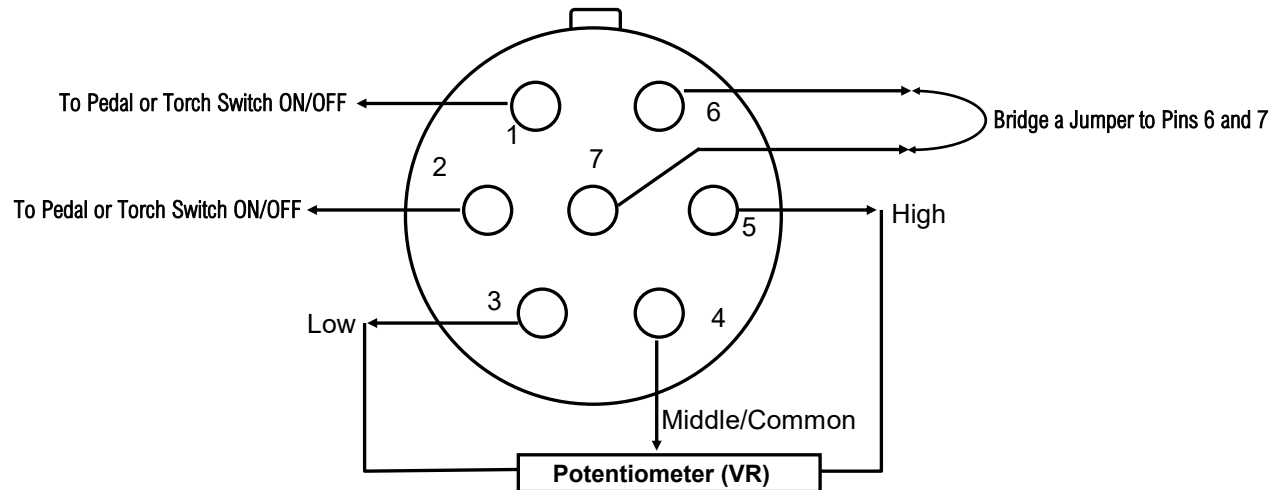

Troubleshooting

Common Welding Issues

NO.	Trouble	Possible Cause	Solution
1.	Unit is switched on, but the power light isn't on.	Switch damaged. Service Breaker/ Input Line Damaged.	Check. Replace.
2.	After welding machine is overheating .	Duty Cycle Exceeded. Fan damaged and not running. Fan connector plus is loose. Temp Sensor damaged Unit is dirty	Do Not Turn off if fan is running. Set fan to run continuously. Allow to cool while running and unit should automatically reset. Allow to continue to cool for no less than 15 minutes after duty cycle is exceeded, even if the unit resets before this time. Replace. Check. Reinstall. Check operating temperature in background menu and check fan operation. Check and clean.
3.	When switch/pedal is pressed, no gas flows.	Empty Cylinder/ Closed Valve. Regulator Faulty/shut off. Solenoid Dirty/Stuck Shut. Damaged PCB.	Check. Replace/Open Valve. Check regulator and cylinder. Check. Clean or replace. (Contact Everlast Technical Support). Contact Everlast Technical Support.
4.	When switch/pedal is released gas continues to flow after Post-Flow cycle has timed out. May happen irregularly, or when unit is turned on.	Solenoid Dirty/Stuck. Excess moisture from Argon Cylinder.	Disassemble and clean, or replace. (Contact Everlast Technical Support). Install a dryer inline to remove moisture. Solenoid may need to be cleaned or replaced.
5.	Intermittent, wandering arc.	Work Clamp not connected directly to part being welded. Work Clamp worn/damaged. Torch height too high. Wrong Polarity	Reconnect. Replace. Reduce TIG torch height to under 1/8". Drag Welding Rod (Stick). Torch should be in negative for all TIG work. Stick should be positive.
6.	Arc will not start unless lift started.	HV/HF board is damaged or disconnected HV/HF settings are incorrect HF Start not selected.	Make sure unit is set to HF Start. Adjust Settings
7.	Tungsten is rapidly consumed.	Inadequate gas flow. Too small of tungsten. Wrong shielding gas. Using green tungsten. Wrong polarity. Possible contamination of shielding gas from gas supplier. Welder is too close to work.Fans are blowing gas.	Check gas flow. Check for Leaks throughout system/regulator/tank. Check for 100% Argon. Use Lanthanated 2% or any other type besides Green (Pure) or Zirconiated. Put torch in Negative terminal. Move unit 6 to 8 ft away.
8.	Tungsten is contaminated, arc changes to a green color.	Tungsten is dipping into weld. Too long of stick-out. Tungsten is melting.	Check and adjust stick out to 1/8". Reduce stick-out to less than 1/4". Reduce amperage or increase tungsten size.
9.	Porosity of the Weld. Discolored weld color. Tungsten is discolored.	Low flow rate of shielding gas. High flow rate of shielding gas. Tungsten stick-out is too far. Too short of post flow period. Wrong TIG cup size. Possible gas leaks internally or externally due to loose fittings. Base metal is contaminated with dirt or grease.	Increase flow rate on regulator. Check for kinks in tubing. Increase post-flow time. Reduce stick-out to less than 1/4". Increase cup size, or use gas lens. Clean metal thoroughly with approved metal cleaner, or use acetone and a rag to clean metal.
10.	Weld quality is poor. Weld is dirty/oxidized, or porous.	Drafty conditions. The welder is located on the workpiece and is blowing gas off due to fan activity. Solenoid is sticking. Too short of pre-flow or post-flow.	Eliminate drafts. Move welder. Check if there is sufficient shielding gas left in tank. Check gas flow. Adjust for higher flow of gas. Listen for audible click of gas solenoid. If no click is heard, then contact Everlast Support. Clean weld properly. Increase pre flow or post flow.
11.	Unstable Arc.	Poorly ground or shaped tungsten. Bad work clamp connection. Metal is indirectly connected through table or other item.	Regrind to proper point. Wrong polarity. Place torch in DC negative (-). Connect work clamp directly to item being welded.
12.	AC TIG will not weld properly.	Wrong polarity. Work clamp is not connected direct to work. Balled Tungsten. AC Balance too high. AC Frequency too low. Contaminated Gas.	Check and change immediately. TIG torch is always negative. Put clamp direct to work. Sharpen Tungsten. Do not use form ball. Set for approximately 30%. Increase to 50 Hz or higher. Source new cylinder or new supplier.
13.	Other.		Contact Everlast.

Troubleshooting

Error Codes

TROUBLE CODE WITH WARNING LIGHT/UNIT STOPS WELDING BUT IS TURNED ON.	DIAGNOSIS
E01	OVER TEMPERATURE/ DUTY CYCLE EXCEEDED. Allow unit to rest for 15 minutes while running. The unit should reset. If it does not or condition reoccurs, check for obstacles near unit blocking cooling. Then clean unit internals paying close attention to boards and heat sinks. Make sure unit is unplugged for 10 minutes before opening up for cleaning. Check for proper fan operation.
E02	OVER OR UNDER CURRENT. Check power input cable for length/size, check input voltage. Running on poor quality power supply or dirty power from generator. Possible Internal Issue.
E05	TORCH SWITCH IS STUCK CLOSED. This simply means that the arc has been trying to start and for too long. If this does not clear after releasing the switch, turn off unit immediately and check torch switch for stuck contact. If the pilot arc or HF Start is engaged without attempting to cut or weld for more than 3 seconds this will activate.
OTHER	CONTACT EVERLAST

Maintenance

What is the Typhoon Maintenance Schedule ?

This unit uses a HV electronic device to simulate an HF start. There are no points to maintain or point gaps to adjust.

However, every 3 to 4 months (or more depending upon use level), the unit should be opened up for inspection and cleaning. Use compressed dry air to blow out dust. Take care to remove any metal dust or other buildup from fan blades and vents. Take time to check the seating of all connectors and accessible wires. *Opening the unit up for cleaning does not void the warranty, but rather preserves it. Neglected cleaning can lead to failures of boards and components. Cleaning is a necessary component of operation to maximizing service life and maintaining warranty. Warranty claims submitted that are a result of neglect or abuse may not be covered under warranty.*

CAUTION! *Use Safety glasses and protective equipment when using compressed air or attempting to service this equipment!*

To Access and Clean the Unit:

1. Unplug unit for 10 minutes before starting to allow capacitors to discharge.
2. Remove front, middle and rear handle screws. (If handles are not installed, remove top bezel screws on front and rear. Remove any top mounted screws used in lieu of handles.
3. Remove handles.
4. Remove rear plastic bezel screws. Be sure to remove the screws located on the bottom of the bezel.
5. Remove rear bezel. Do not attempt to remove underlying metal case end. The case end is a structural part of the frame.
6. Remove the main green cover screws.
7. Insert fingers under bottom edge of the cover, near the rear of the cover. Gently spread the cover about 1 inch.
8. Slide the main cover to the rear and up carefully to clear any wires or obstructions.
9. When the cover has been removed, use dry compressed air to gently blow off boards and connectors.
10. Check to make sure all connectors are clean and fully seated. Make sure no wires have been unseated from the connectors themselves.
11. Clean bezel vents and fan blades. Fan blades accumulate build-up which can cause reduced cooling efficiency, vibration and eventually failure.
12. Once cleaned, reassemble unit in reverse order.

IMPORTANT: *Never remove the front cover or upper operator's panel unless instructed by Everlast.*

