

# POWER SOURCE WIRE DIAGRAM

 **Check the output power before turn the machine on!**

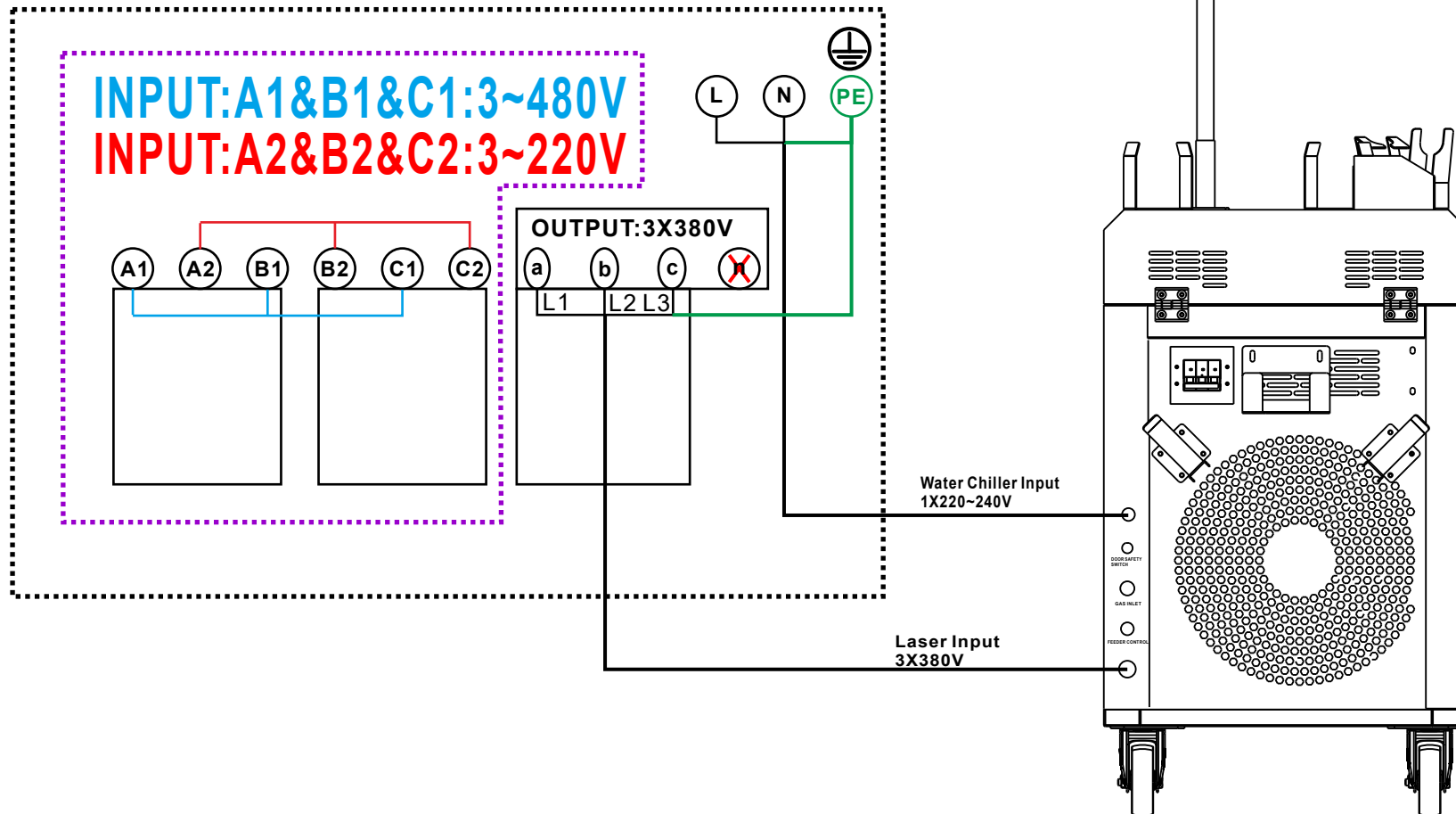

# POWER SOURCE WIRE DIAGRAM

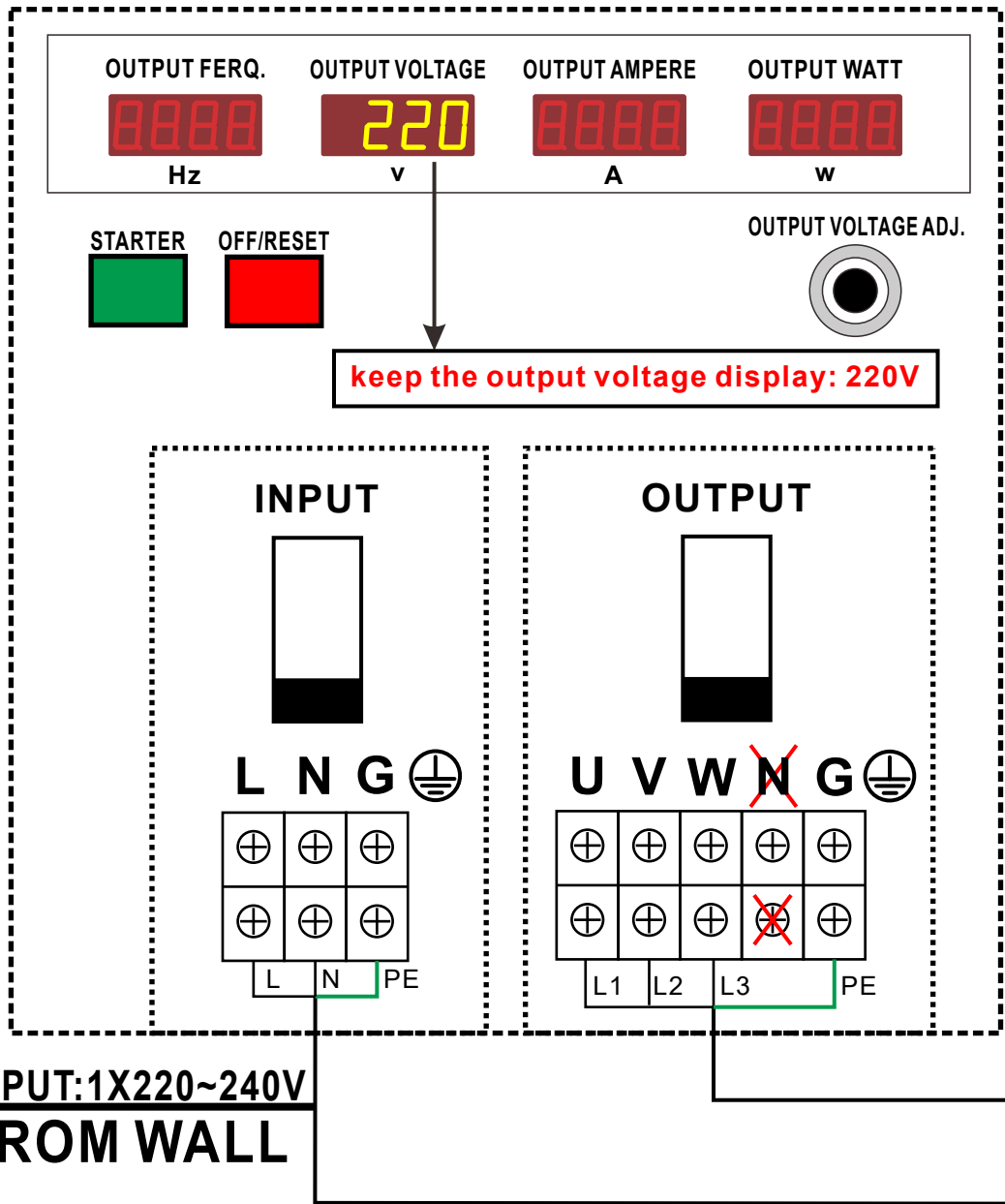

**⚠ Check the output power before turn the machine on!**

**INPUT: 1X220~240V FROM WALL**

